

# TOTO®

## NEOREST TOILET

### CW997DF/CH, CW998DF/CH

## NEOREST



### Installation Guide Installationsanleitung Guide d'installation Manuale di installazione

<b>Cautions and warnings . . . . .</b>	<b>2</b>
<b>Before Installing the NEOREST . . . . .</b>	<b>3</b>
<b>Vorsichtsmaßnahmen und Warnungen . . . . .</b>	<b>4</b>
<b>Vor der Installation des NEOREST . . . . .</b>	<b>5</b>
<b>Mises en garde et avertissements . . . . .</b>	<b>6</b>
<b>Avant d'installer le NEOREST . . . . .</b>	<b>7</b>
<b>Avvisi di pericolo e attenzione . . . . .</b>	<b>8</b>
<b>Prima di installare il NOEREST . . . . .</b>	<b>9</b>
<b>Included parts . . . . .</b>	<b>10</b>
<b>Required tools . . . . .</b>	<b>11</b>
<b>Parts . . . . .</b>	<b>11</b>
<b>Optional accessories . . . . .</b>	<b>11</b>

Introduction

<b>Meaning of the indications . . . . .</b>	<b>12</b>
<b>Installing the NEOREST . . . . .</b>	<b>12</b>

Attaching parts

<b>Testing the operation of the NEOREST . . . . .</b>	<b>19</b>
<b>Cleaning the water supply filter . . . . .</b>	<b>26</b>
<b>Attaching the cover panels . . . . .</b>	<b>29</b>

Others

#### To installation contractors:

Please explain to the customer the functions of the NEOREST and how to use them. If the theft prevention parts for the stick remote control are not installed, give them to the customer. In new buildings or other places where there will be a significant time until the customer receives the product, please disconnect the mains plug.

#### Für Installateure:

Erklären Sie dem Kunden bitte die Funktions- und Bedienungsweise des NEORESTs. Wenn die Teile zur Diebstahlverhütung zur Befestigung der Fernbedienung nicht angebracht sind, geben Sie sie dem Kunden. In neuen Gebäuden oder an Orten, wo es geraume Zeit dauert, bis der Kunde das Gerät zum ersten Mal benutzt, ziehen Sie bitte den Netzstecker.

#### Aux prestataires d'installation:

Veuillez expliquer au client les fonctions du NEOREST et comment les utiliser. Si les éléments antivols de la barre de télécommande n'ont pas été installés, remettez-les au client. Dans de nouveaux bâtiments où d'autres lieux où une durée importante s'écoulera avant que le client ne reçoive le produit, veuillez déconnecter la prise secteur.



#### Per gli installatori:

Si prega di illustrare ai clienti le funzioni del NEOREST e le loro modalità di utilizzo. Se i componenti antifurto del telecomando "a bastoncino" non verranno installati, consegnarli al cliente. Negli edifici nuovi e in altri luoghi in cui dovrà passare molto tempo prima che il cliente inizi a utilizzare il prodotto, staccare la spina di alimentazione.

# Cautions and warnings

Before installing your NEOREST, be sure to read the following installation instructions. Install the product only as described in this guide.

Follow all safety precautions and warnings.



 <b>WARNING</b>	<p><b>When this appears next to a topic, this indicates that misoperation could result in death or serious injury.</b></p>	 <b>CAUTION</b>	<p><b>When this appears next to a topic, this indicates that misoperation may result in injury or physical damage.</b></p>
---	--	---	--

**Symbol example**

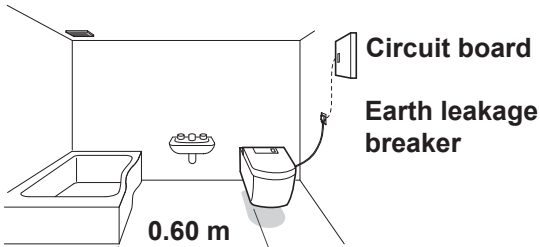

	<p>The  symbol indicates something that is prohibited.</p>		<p>The  symbol indicates something that must be done.</p>
---	---	---	--

- This equipment is Class 1, so it is necessary to attach it to an earthed connection.
- Install this equipment close to a mains socket.
- Use the new hose set included with this equipment. Do not reuse an old hose set.

## **WARNING**

 Required	<ul style="list-style-type: none"> <li>• Since this is electronic equipment, do not locate it in a place where it might be splashed or otherwise become wet. Likewise, do not locate it in a humid place where water could drip onto the surface of the NEOREST. When using it in a bathroom, install a ventilation fan or ventilation opening, so that the bathroom has sufficient airflow. Install the NEOREST at least 0.6 m away from any bathtub. (Failure to observe this caution may result in fire or electrical shock.)</li> <li>• Prepare the socket for the electrical wiring as follows. (Failure to observe this caution may result in fire or electrical shock.)                         <ol style="list-style-type: none"> <li>a. Provide electric current to the socket (device) using a differential residual electric current device (DDR) with a released current that does not exceed 30 mA.</li> <li>b. Locate the socket (device) and its wiring plug at least 0.6 m from the outside edge of a shower chamber or bathtub.</li> </ol> <p>* Confirm that the wiring for items a and b above has been completed. If the wiring has not been completed, request completion from the business that installed the unit.</p> </li> <li>• Be sure to install an earth wire in a place where connection is ensured. (If the earth wire is not installed, electric shocks could occur if there is a malfunction or a short circuit.)                      Note:                      Use copper wire with a diameter of 1.6 mm or more and with an earth resistance of 100 Ω or less.                      * If the earth wire has not been installed, request installation from the business that installed the unit.</li> <li>• Always insert the electrical cord completely into the socket (220-240 V AC, 50 Hz). (Failure to observe this caution may result in fire or electrical shock.)</li> <li>• Make the connection so that the electrical plug is easy to reach.</li> <li>• Always connect the NEOREST to the cold water supply. (Failure to do so could cause burns or malfunction of the equipment.)</li> <li>• Follow the installation requirements for the country in which the NEOREST is being installed.</li> </ul>	<p style="text-align: center;"><b>Ventilation fan or ventilation opening</b></p>  <p style="text-align: right;"><b>Circuit board</b> <b>Earth leakage breaker</b></p>
	<ul style="list-style-type: none"> <li>• Avoid direct impacts to the ceramic components as this could break the ceramic and result in injury, property damage, or water leakage.</li> <li>• When moving the product by itself, always hold it by the ceramic part. Damage, injury, equipment breakage or water leakage could occur if you hold it by any other part and move it.</li> </ul>	
 Prohibited	<ul style="list-style-type: none"> <li>• Use only tap water or potable well water (groundwater). (Use of other water could cause skin inflammation or other problems.)</li> <li>• Do not use this product with any power supply other than specified (220-240 V AC, 50 Hz). (Failure to observe this caution may result in fire or electrical shock.)</li> </ul>	

**⚠ CAUTION**

 Required	<ul style="list-style-type: none"> <li>• After cleaning the water filter, thoroughly tighten the drain valve with built-in water filter. (Failure to do so could cause a water leak.)</li> </ul>
	<ul style="list-style-type: none"> <li>• Follow the Installation Guide thoroughly during installation. (Failure to attach things correctly could cause water leaks.)</li> </ul>
 Prohibited	<ul style="list-style-type: none"> <li>• Do not detach the drain valve with built-in water filter while the water shut-off valve is still open. (Doing so will cause water to spill.)</li> </ul>
	<ul style="list-style-type: none"> <li>• Do not bend or crush the water supply hose. (This could cause a water leak.)</li> </ul>
	<ul style="list-style-type: none"> <li>• Do not lift the NEOREST by the seat or toilet lid. (Injury could result if the main NEOREST unit becomes dislodged and falls.)</li> </ul>

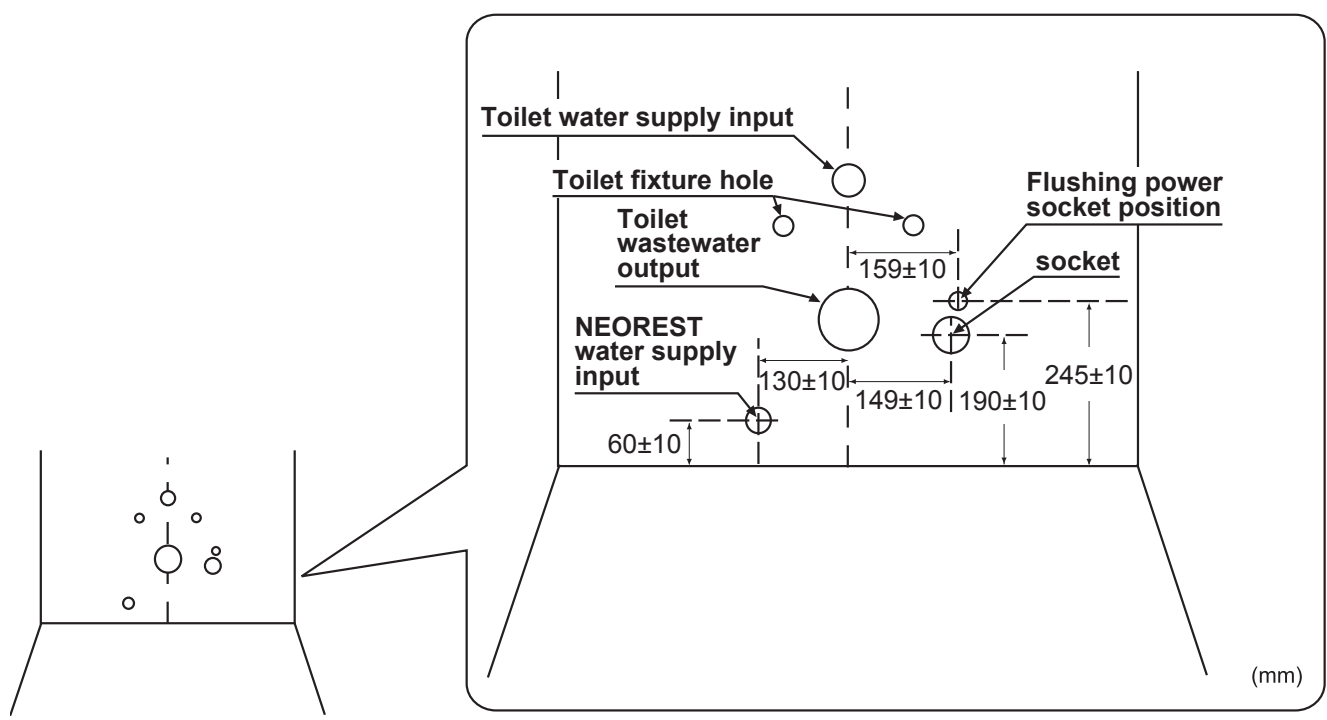

**Before Installing the NEOREST**

1. Do not transmit electrical current or supply water to the unit until the installation process is complete.
2. Do not damage the connected parts at the end of the water supply hose.
3. The power voltage is 220-240 V AC (50 Hz). The rated energy consumption is 346-409 W. Use wiring and electrical sockets that are appropriate for this level of power. (Independent wiring is recommended.)
4. The power cord is 1.0 m long. Confirm that a mains socket is installed within reach to allow easy installation and removal of the NEOREST.
5. Use a water supply with pressure between 0.1 - 1.0 Mpa.
6. The water temperature range should be between 0 - 35 °C.
7. Do not use any water supply hose other than that included with the product.
8. Before installation, confirm that the NEOREST water supply input, the socket and the flushing power socket position are in their prescribed positions.



# Vorsichtsmaßnahmen und Warnungen

Lesen Sie vor der Installation Ihres NEOREST die folgenden Installationsanweisungen bitte gut durch. Installieren Sie das Produkt bitte nur so, wie es in der Anleitung beschrieben ist. Beachten Sie bitte alle Vorsichtsmaßnahmen und Warnungen.



 <b>WARNUNG</b>	<p>Wenn ein Abschnitt mit diesem Symbol gekennzeichnet ist, wird darauf hingewiesen, dass bei fehlerhafter Handhabung die Gefahr von schweren oder gar tödlichen Verletzungen besteht.</p>	 <b>VORSICHT</b>	<p>Wenn ein Abschnitt mit diesem Symbol gekennzeichnet ist, wird darauf hingewiesen, dass bei fehlerhafter Handhabung möglicherweise Verletzungsgefahr oder die Gefahr von Sachschäden besteht.</p>
---	--	--	---

## Beispielsymbole

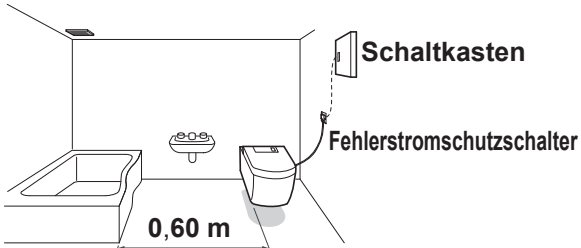

	<p>Das Symbol  gibt an, dass etwas verboten ist.</p>		<p>Das Symbol  weist auf etwas hin, das getan werden muss.</p>
---	---	---	---

- Bei diesem Gerät handelt es sich um ein Gerät der Klasse 1, es muss daher an eine Steckdose mit Schutzerde angeschlossen werden.
- Installieren Sie das Gerät in der Nähe einer Netzsteckdose.
- Verwenden Sie die neuen, mit diesem Gerät gelieferten Schläuche. Verwenden Sie keine alten Schläuche.

## **WARNUNG**

 Erforderlich	<ul style="list-style-type: none"> <li>• Da es sich hierbei um ein elektronisches Gerät handelt, stellen Sie es nicht an einem Ort auf, wo es Spritzwasser oder Nässe ausgesetzt werden könnte. Stellen Sie es nicht an einem feuchten Ort auf, wo Wasser auf die Oberfläche des NEOREST-Geräts tropfen könnte. Wenn Sie das Gerät in einem Bad verwenden, installieren Sie ein Lüftungsgebläse oder einen Lüftungsschacht, so dass das Bad ausreichend belüftet ist. Installieren Sie das NEOREST-Gerät in einer Entfernung von mindestens 0,6 m zu einer Badewanne. (Ansonsten besteht die Gefahr, dass ein Feuer entsteht oder Sie einen elektrischen Schock bekommen.)</li> <li>• Beachten Sie beim Elektroanschluss unbedingt folgende Hinweise. (Ansonsten besteht die Gefahr, dass ein Feuer entsteht oder Sie einen elektrischen Schock bekommen.)                         <ul style="list-style-type: none"> <li>a. Die Steckdose (das Geräts) für die Stromversorgung muss mit einer Fehlerstromschutzschaltung (RCD) mit einem Auslösestrom von maximal 30 mA gesichert sein.</li> <li>b. Die Steckdose (das Gerät) und der Stecker müssen sich mindestens 0,6 m von der Außenkante einer Duschkabine oder Badewanne entfernt befinden.</li> </ul> <p>* Vergewissern Sie sich, dass die Verkabelung wie unter a. und b. beschrieben vorgenommen wurde. Wenn die Verkabelung nicht entsprechend vorgenommen wurde, wenden Sie sie diesbezüglich an das Geschäft, in dem Sie das Gerät gekauft haben.</p> </li> <li>• Es muss ein Schutzleiter verlegt sein, und zwar so, dass die Verbindung gewährleistet ist. (Wenn kein Schutzleiter verlegt ist, kann es bei einer Fehlfunktion oder einem Kurzschluss zu einem elektrischen Schlag kommen.) Hinweis: Verwenden Sie Kupferdraht mit einem Durchmesser von mindestens 1,6 mm und mit einem Erdungswiderstand von maximal 100 Ω. * Wenn kein Schutzleiter verlegt ist, wenden Sie sie diesbezüglich an das Geschäft, in dem Sie das Gerät gekauft haben.</li> <li>• Stecken Sie den Netzstecker immer ganz in die Steckdose (220-240 V Wechselstrom, 50 Hz). (Ansonsten besteht die Gefahr, dass ein Feuer entsteht oder Sie einen elektrischen Schock bekommen.)</li> <li>• Achten Sie darauf, dass der Netzstecker leicht zugänglich ist.</li> <li>• Schließen Sie das NEOREST immer an die Kaltwasserversorgung an. (Bei Nichtbeachtung kann es zu Verbrennungen und Fehlfunktionen des Geräts kommen.)</li> <li>• Befolgen Sie bitte die Installationsanweisungen für das Land, in dem das NEOREST-Gerät installiert wird.</li> </ul>	<p><b>Lüfter oder Lüftungsöffnung</b></p>  <p><b>Schaltkasten</b> <b>Fehlerstromschutzschalter</b></p> <p><b>0,60 m</b></p>
	<ul style="list-style-type: none"> <li>• Vermeiden Sie direkte Einwirkungen auf die Keramikkomponenten, da dies das Keramik beschädigen könnte und somit zu Verletzungen, Schäden oder undichten Stellen führen könnte.</li> <li>• Wenn Sie das Produkt selbst bewegen, halten Sie es immer am Keramikteil fest. Wenn Sie es beim Bewegen an einem anderen Teil festhalten, kann dies zu Schäden, Verletzungen, zum Abbrechen der Geräte oder zu undichten Stellen führen.</li> </ul>	
 Verboten	<ul style="list-style-type: none"> <li>• Verwenden Sie ausschließlich Leitungswasser oder als Leitungswasser geeignetes Brunnenwasser (Grundwasser). (Bei Verwendung anderer Wasserquellen kann es zu Hautreizungen und anderen Problemen kommen.)</li> <li>• Benutzen Sie für dieses Produkt keine andere als die angegebene Stromversorgung (220-240 V Wechselstrom, 50 Hz). (Ansonsten besteht die Gefahr, dass ein Feuer entsteht oder Sie einen elektrischen Schock bekommen.)</li> </ul>	

## ⚠ VORSICHT

 Erforderlich	<ul style="list-style-type: none"> <li>Nach dem Reinigen des Wasserfilters müssen Sie das Ablaufventil mit eingebautem Wasserfilter fest schließen. (Bei Nichtbeachtung kann Wasser austreten.)</li> </ul>
	<ul style="list-style-type: none"> <li>Befolgen Sie bei der Installation die Anweisungen in der Installationsanleitung genau. (Bei fehlerhaften Verbindungen kann Wasser austreten.)</li> </ul>
 Verboten	<ul style="list-style-type: none"> <li>Nehmen Sie nicht das Ablaufventil mit eingebautem Wasserfilter nicht ab, solange das Wasserabsperrventil geöffnet ist. (Andernfalls strömt Wasser aus.)</li> </ul>
	<ul style="list-style-type: none"> <li>Biegen und quetschen Sie den Wasserzulaufschlauch nicht. (Andernfalls kann Wasser austreten.)</li> </ul>
	<ul style="list-style-type: none"> <li>Heben Sie das NEOREST nicht am Sitz oder am Toilettendeckel hoch. (Sollte sich das NEOREST-Hauptgerät ablösen und herunterfallen, kann dies zu Verletzungen führen.)</li> </ul>

## Vor der Installation des NEOREST

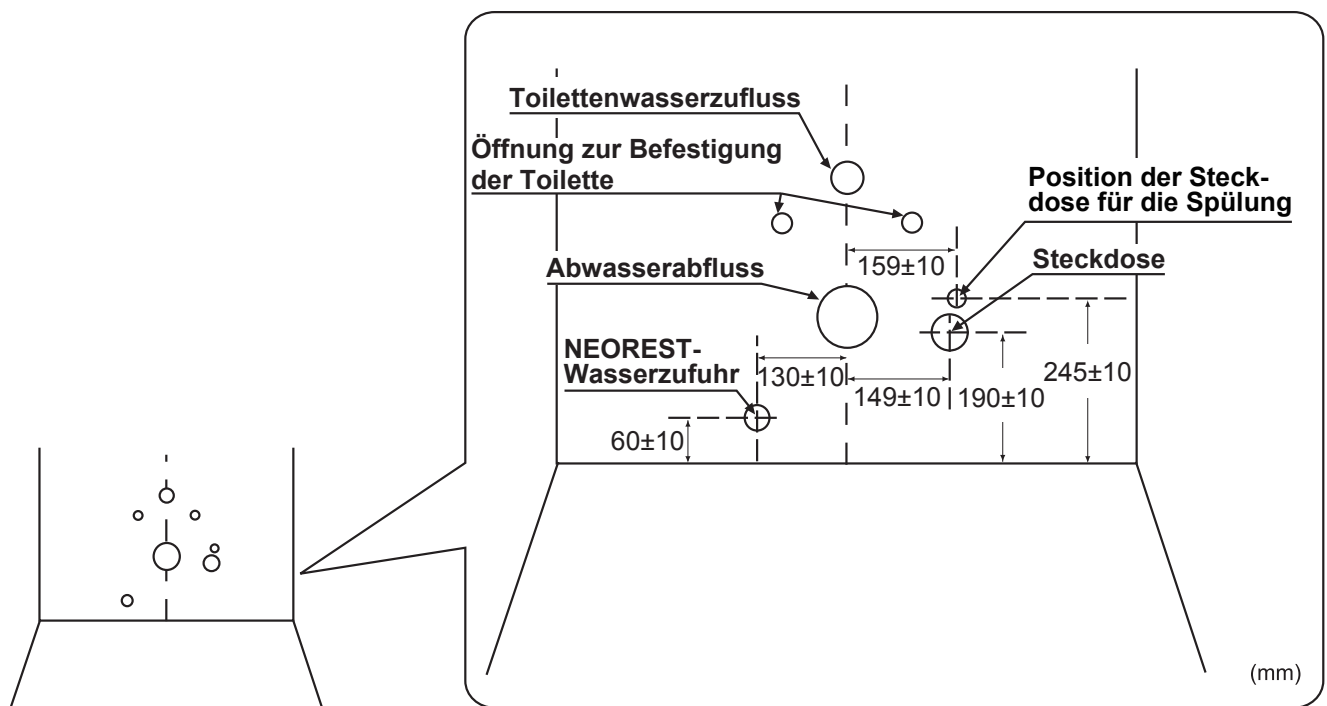

1. Schließen Sie die Installation vollständig ab, bevor Sie das Gerät mit Strom oder Wasser versorgen.
2. Beschädigen Sie die an das Ende des Wasserzulaufschlauchs angeschlossenen Teile nicht.
3. Die Betriebsspannung beträgt 220-240 V Wechselstrom (50 Hz). Die Nennleistungsaufnahme beträgt 346-409 W. Achten Sie darauf, dass die Verkabelung und die Steckdose auf diese Anschlusswerte ausgelegt sind. (Es empfiehlt sich, das Gerät an einen eigenen Stromkreis anzuschließen.)
4. Das Netzkabel ist 1,0 m lang. Vergewissern Sie sich, dass in der Nähe eine leicht zugängliche Netzsteckdose installiert ist, so dass sich das NEOREST leicht anschließen und trennen lässt.
5. Der Wasserversorgungsdruck muss zwischen 0,1 und 1,0 MPa liegen.
6. Die Wassertemperatur muss zwischen 0 und 35 °C liegen.
7. Benutzen Sie keinen anderen als den mitgelieferten Wasserzulaufschlauch.
8. Stellen Sie vor der Installation sicher, dass sich die NEOREST-Wasserzufuhr, die Steckdose und die Steckdose für die Spülungen den vorgeschriebenen Positionen befinden.



## Mises en garde et avertissements

Avant d'installer votre NEOREST, assurez-vous de lire les instructions d'installation suivantes. Installez ce produit en suivant exclusivement la procédure décrite dans ce guide.

Suivez toutes les précautions et les avertissements de sécurité.



 <b>AVERTISSEMENT</b>	<p>Lorsque ce symbole apparaît en regard d'une rubrique, cela indique que toute utilisation incorrecte pourrait entraîner la mort ou une blessure grave.</p>	 <b>MISE EN GARDE</b>	<p>Lorsque ce symbole apparaît en regard d'une rubrique, cela indique que toute utilisation incorrecte peut entraîner une blessure ou un dommage physique.</p>
---	--	---	--

### Exemple de symbole

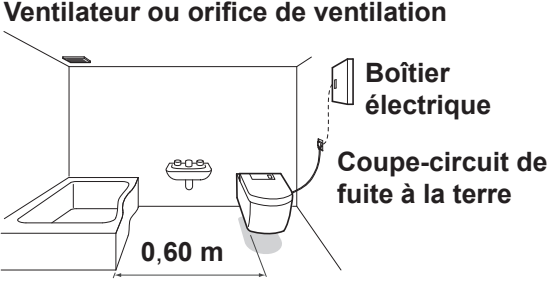

	<p>Le symbole  indique que quelque chose est interdit.</p>		<p>Le symbole  indique que quelque chose doit être fait.</p>
---	---	---	---

- Ce matériel est de catégorie 1, c'est pourquoi il est nécessaire de le connecter à la terre.
- Installez ce matériel près d'une prise secteur.
- Utilisez le nouveau jeu de flexibles inclus avec cet appareil. Ne réutilisez pas un ancien jeu de flexibles.

## AVERTISSEMENT

 <b>Requis</b>	<ul style="list-style-type: none"> <li>• Dans la mesure où il s'agit d'un matériel électronique, ne le placez pas à un emplacement où il pourrait être éclaboussé ou soumis à l'humidité. De même, ne le placez pas dans un lieu humide où de l'eau pourrait couler sur la surface du NEOREST. Lorsque vous l'utilisez dans une salle de bain, installez un ventilateur ou un orifice de ventilation afin que la salle de bain soit suffisamment ventilée. Installez le NEOREST à au moins 0,6 m d'une baignoire. (Le non-respect de cette mise en garde pourrait entraîner un incendie ou l'électrocution.)</li> <li>• Préparez la prise pour le câblage électrique en procédant comme suit. (Le non-respect de cette mise en garde pourrait entraîner un incendie ou l'électrocution.)             <ol style="list-style-type: none"> <li>a. Alimentez la prise en courant électrique (appareil) à l'aide d'un appareil électrique différentiel à double vitesse de transfert émettant une puissance ne dépassant pas 30 mA.</li> <li>b. Placez la prise femelle (appareil) à 0,6 m minimum du bord extérieur d'une douche ou d'une baignoire.                 <ul style="list-style-type: none"> <li>* Vérifiez que le câblage des éléments a et b ci-dessus a été réalisé. Si le câblage n'est pas réalisé, demandez à l'entreprise ayant installé l'appareil de le faire.</li> </ul> </li> </ol> </li> <li>• Assurez-vous d'installer un conducteur de terre dans un lieu où ce type de branchement est possible. (Si le conducteur de terre n'est pas installé, des chocs électriques pourraient survenir en cas de dysfonctionnement ou de court-circuit.) Remarque: Utilisez un fil de cuivre d'un diamètre de 1,6 mm ou plus et d'une résistance à la terre de 100 Ω ou inférieure. * Si le conducteur de terre n'a pas été installé, demandez à l'entreprise ayant installé l'appareil de le faire.</li> </ul>	 <b>Ventilateur ou orifice de ventilation</b> <b>Boîtier électrique</b> <b>Coupe-circuit de fuite à la terre</b> <b>0,60 m</b>
	<ul style="list-style-type: none"> <li>• Insérez toujours le câble électrique complètement dans la prise (220-240 V CA, 50 Hz). (Le non-respect de cette mise en garde pourrait entraîner un incendie ou l'électrocution.)</li> <li>• Faites le branchement de façon à ce que la prise électrique soit facile à atteindre.</li> <li>• Connectez toujours le NEOREST à l'alimentation en eau froide. (Le non-respect de cette instruction pourrait entraîner des brûlures ou un dysfonctionnement de l'appareil.)</li> <li>• Suivez les exigences d'installation pour le pays dans lequel le NEOREST est installé.</li> </ul>	
	<ul style="list-style-type: none"> <li>• Evitez tout impact direct sur les éléments en céramique, car cela risquerait de les briser et de provoquer des blessures, des dégâts ou une fuite d'eau.</li> </ul>	
	<ul style="list-style-type: none"> <li>• Lorsque vous déplacez le produit proprement dit, tenez-le toujours par la partie en céramique. Si vous le déplacez en le saisissant ailleurs, vous risquez de provoquer des dégâts, de vous blesser, de le briser ou d'entraîner une fuite d'eau.</li> </ul>	
 <b>Interdit</b>	<ul style="list-style-type: none"> <li>• N'utilisez que de l'eau du robinet ou de l'eau d'un puits potable (provenant de nappes). (L'utilisation d'autres types d'eau pourrait entraîner une inflammation de la peau ou d'autres problèmes.)</li> <li>• N'utilisez pas ce produit avec une alimentation électrique autre que celle spécifiée (220-240 V CA, 50 Hz). (Le non-respect de cette mise en garde pourrait entraîner un incendie ou l'électrocution.)</li> </ul>	

## ⚠ MISE EN GARDE

 <b>Requis</b>	<ul style="list-style-type: none"> <li>Après avoir nettoyé le filtre à eau, serrez fermement le robinet de vidange avec filtre à eau intégré. (Le non-respect de cette mise en garde pourrait entraîner une fuite.)</li> <li>Suivez le guide d'installation avec attention pendant l'installation. (Un branchement incorrect pourrait entraîner des fuites d'eau.)</li> </ul>
 <b>Interdit</b>	<ul style="list-style-type: none"> <li>Ne détachez pas le robinet de vidange avec filtre à eau intégré lorsque le robinet de sectionnement est encore ouvert. (De l'eau pourrait se déverser.)</li> <li>Ne pliez pas ou n'écrasez pas le flexible d'alimentation en eau. (Cela pourrait entraîner une fuite d'eau.)</li> <li>Ne soulevez pas le NEOREST par le siège ou l'abattant. (Une blessure pourrait survenir si l'unité NEOREST principale se déloge et tombe.)</li> </ul>

## Avant d'installer le NEOREST

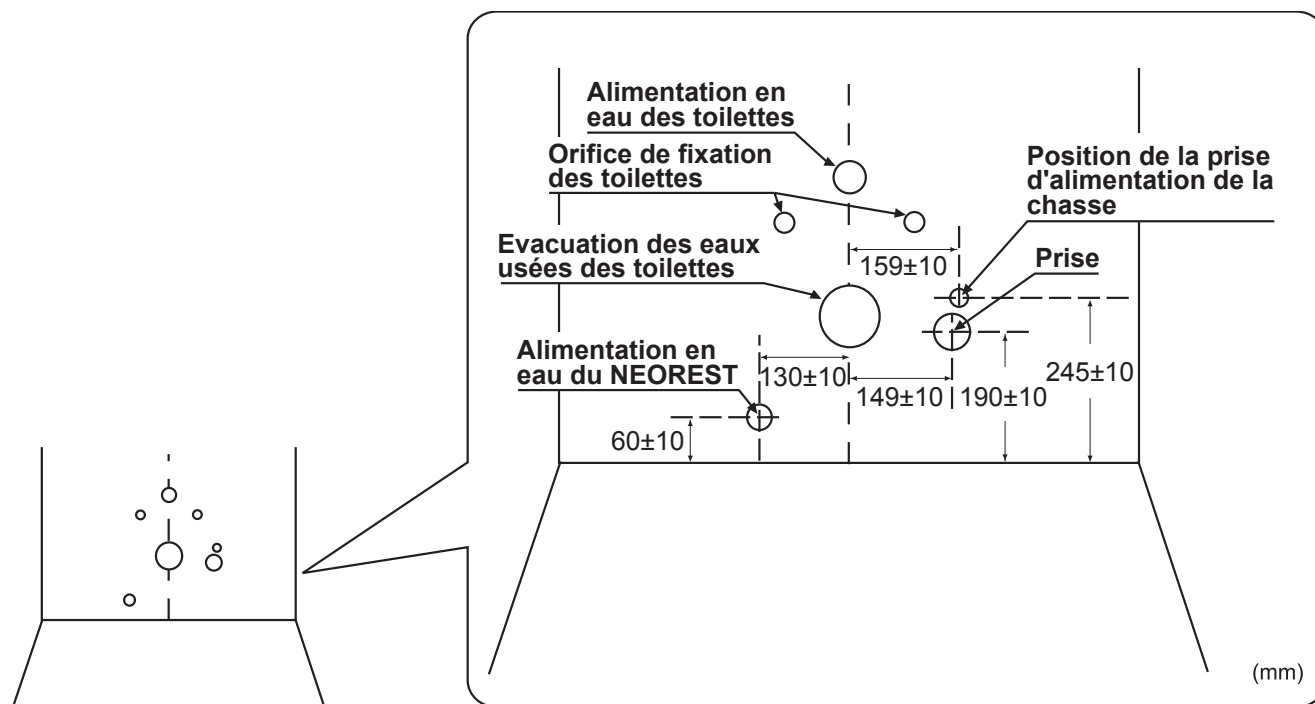

- Ne transmettez pas de courant électrique et n'alimentez pas l'unité en eau avant que la procédure d'installation ne soit terminée.
- N'endommagez pas les pièces connectées à l'extrémité du flexible d'alimentation en eau.
- La tension d'alimentation est de 220-240 V CA (50 Hz). La consommation d'énergie nominale est de 346-409 W. Utilisez des câbles et des prises électriques adaptés à ce niveau d'alimentation. (Un câblage indépendant est recommandé.)
- Le cordon d'alimentation mesure 1,0 m de long. Vérifiez qu'une prise secteur est installée à portée afin de faciliter l'installation et le retrait du NEOREST.
- Utilisez une alimentation en eau d'une pression située entre 0,1 et 1,0 Mpa.
- La plage de température de l'eau doit être située entre 0 et 35 °C.
- Utilisez exclusivement le flexible d'alimentation en eau fourni avec le produit.
- Avant l'installation, vérifiez si l'alimentation en eau du NEOREST, la prise et la prise d'alimentation de la chasse occupent les positions prescrites.







## Avvisi di pericolo e attenzione

Prima di installare il NEOREST, leggere le seguenti istruzioni di installazione. Per l'installazione, adottare esclusivamente le procedure riportate nel presente manuale.

Rispettare tutte le istruzioni di sicurezza e le indicazioni riportate negli avvisi.



 <b>PERICOLO</b>	<p>I paragrafi preceduti da questa indicazione contengono descrizioni importanti. In caso di inosservanza, si possono verificare gravi infortuni, anche mortali.</p>	 <b>ATTENZIONE</b>	<p>I paragrafi preceduti da questa indicazione contengono descrizioni importanti. In caso di inosservanza, si possono verificare infortuni o danni alle cose.</p>
--	--	--	---

### Esempio di simbolo

	<p>Il simbolo  indica operazioni vietate.</p>		<p>Il simbolo  indica operazioni che devono essere eseguite obbligatoriamente.</p>
---	--	---	---



- Questa apparecchiatura è di Classe 1, pertanto è necessario effettuare il collegamento a un sistema di messa a terra.
- L'apparecchiatura deve essere installata in prossimità di una presa di alimentazione.
- Utilizzare il set di tubi nuovi fornito insieme all'apparecchiatura. Non riutilizzare tubi flessibili utilizzati in precedenza.

## PERICOLO

 <b>Obbligatorio</b>	<ul style="list-style-type: none"> <li>• Il NEOREST è un apparecchio elettronico, pertanto non deve essere installato in luoghi in cui potrebbe essere spruzzato o bagnato. Analogamente, non deve essere installato in luoghi umidi o in cui l'acqua potrebbe gocciolare sulle sue superfici. Se viene installato in una stanza da bagno, prevedere un impianto di ventilazione o un'apertura per la ventilazione, in modo da garantire un'adeguata circolazione dell'aria. Il NEOREST deve essere installato ad almeno 0,6 m di distanza dalle vasche da bagno. (In caso di mancata osservanza di questa indicazione si potrebbero verificare incendi o scosse elettriche.)</li> <li>• Preparare la presa per il collegamento elettrico attenendosi alle istruzioni sotto riportate. (In caso di mancata osservanza di questa indicazione si potrebbero verificare incendi o scosse elettriche.)             <ol style="list-style-type: none"> <li>a. La presa elettrica deve essere alimentata tramite collegamento a un impianto munito di Dispositivo a corrente Differenziale Residua (DDR) con corrente nominale non superiore a 30 mA.</li> <li>b. La presa e la spina di collegamento devono essere poste ad almeno 0,6 m di distanza dal bordo esterno di una cabina doccia o vasca da bagno.</li> </ol> <p>* Verificare che i collegamenti descritti ai punti a e b siano stati completati. Qualora i collegamenti non siano stati completati, richiedere l'intervento dell'installatore dell'unità.</p> </li> <li>• Si raccomanda di installare il filo di terra in un punto in cui il collegamento possa essere eseguito correttamente. (Se il filo di terra non è installato, in caso di anomalie di funzionamento o cortocircuiti si potrebbero verificare scosse elettriche.) Nota: Utilizzare un filo di rame da almeno 1,6 mm di diametro con una resistenza di terra massima di 100 Ω. * Se il filo di terra non è stato installato, richiedere l'intervento dell'installatore dell'unità.</li> <li>• Il cavo elettrico deve essere sempre inserito a fondo nella presa (220-240 V CA, 50 Hz). (In caso di mancata osservanza di questa indicazione si potrebbero verificare incendi o scosse elettriche.)</li> <li>• Effettuare il collegamento in modo che la spina elettrica sia facilmente raggiungibile.</li> <li>• Il NEOREST deve essere sempre collegato all'ingresso dell'acqua fredda. (In caso contrario, si potrebbero verificare ustioni o anomalie di funzionamento dell'apparecchiatura.)</li> <li>• Per l'installazione, attenersi alle norme in vigore nel paese di utilizzo del NEOREST.</li> </ul>	
	<ul style="list-style-type: none"> <li>• Evitare di urtare i componenti in ceramica poiché, in caso di rottura della ceramica, si potrebbero verificare infortuni, danni alle cose o fuoriuscite d'acqua.</li> <li>• Se si sposta il prodotto da soli, afferrare sempre la parte in ceramica. Afferrando altre parti per spostare il prodotto, si rischia di danneggiarlo e di danneggiare altri prodotti, oppure si potrebbero verificare infortuni o fuoriuscite d'acqua.</li> </ul>	
 <b>Vietato</b>	<ul style="list-style-type: none"> <li>• Utilizzare esclusivamente acqua del rubinetto o acqua sotterranea potabile. (Utilizzando acque di provenienza diversa si potrebbero verificare infiammazioni cutanee o altri problemi.)</li> <li>• Non utilizzare il prodotto con caratteristiche di alimentazione diverse da quanto specificato (220-240 V CA, 50 Hz). (In caso di mancata osservanza di questa indicazione si potrebbero verificare incendi o scosse elettriche.)</li> </ul>	



## ⚠ ATTENZIONE

 <b>Obbligatorio</b>	<ul style="list-style-type: none"> <li>• Dopo aver pulito il filtro dell'acqua, stringere a fondo la valvola di scarico con filtro dell'acqua incorporato. (In caso di mancata osservanza di questa indicazione si potrebbero verificare fuoriuscite d'acqua.)</li> <li>• Durante l'installazione, attenersi scrupolosamente al Manuale di installazione. (Se i collegamenti idraulici non vengono eseguiti correttamente, si potrebbero verificare fuoriuscite d'acqua.)</li> </ul>
 <b>Vietato</b>	<ul style="list-style-type: none"> <li>• Non staccare la valvola di scarico con filtro dell'acqua incorporato mentre la valvola di chiusura acqua è ancora aperta. (In caso contrario, si avrà una fuoriuscita di acqua.)</li> <li>• Non piegare o schiacciare il tubo flessibile di ingresso acqua. (In caso contrario, si potrebbero verificare fuoriuscite di acqua.)</li> <li>• Non sollevare il NEOREST afferrando il sedile o il coperchio del WC. (Se l'unità principale del NEOREST dovesse spostarsi e cadere, si potrebbero verificare infortuni.)</li> </ul>

## Prima di installare il NEOREST

1. Non dare corrente all'apparecchio e non attivare l'erogazione dell'acqua finché l'installazione non sarà completata.
2. Fare attenzione a non danneggiare le parti collegate all'estremità del tubo flessibile di ingresso acqua.
3. La tensione di alimentazione è pari a 220-240 V CA (50 Hz). L'assorbimento nominale è di 346-409 W. Utilizzare cavi e prese adatti a questi valori di potenza. (Si raccomanda di eseguire cablaggi indipendenti.)
4. Il cavo di alimentazione ha una lunghezza di 1,0 m. Verificare che sia presente una presa elettrica nelle vicinanze per agevolare l'installazione e la rimozione del NEOREST.
5. Collegare a una rete idraulica con pressione compresa tra 0,05 e 1,0 Mpa.
6. La temperatura dell'acqua deve essere compresa tra 0 e 35 °C.
7. Non utilizzare tubi diversi dal tubo flessibile di ingresso acqua incluso nella dotazione del prodotto.
8. Prima di procedere all'installazione, verificare che l'ingresso acqua del NEOREST, la presa e la presa di alimentazione dello sciacquone si trovino nelle posizioni previste.

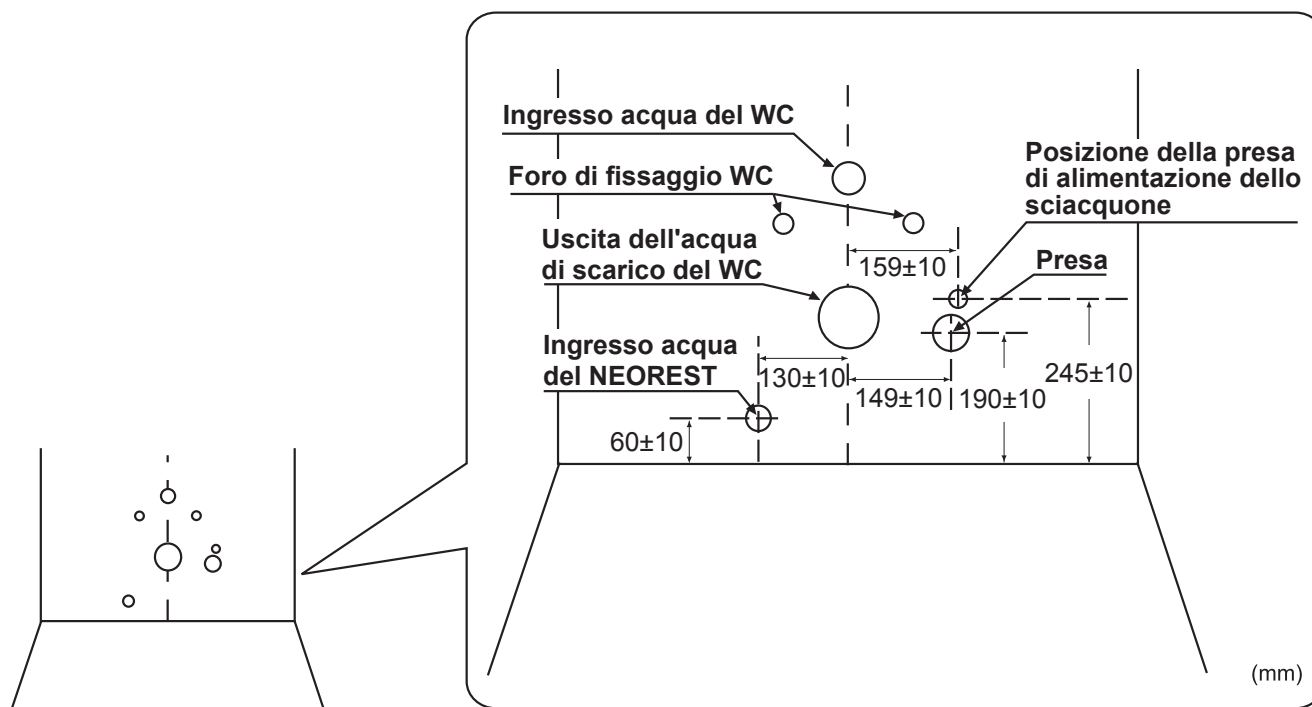

# Included parts

A-1

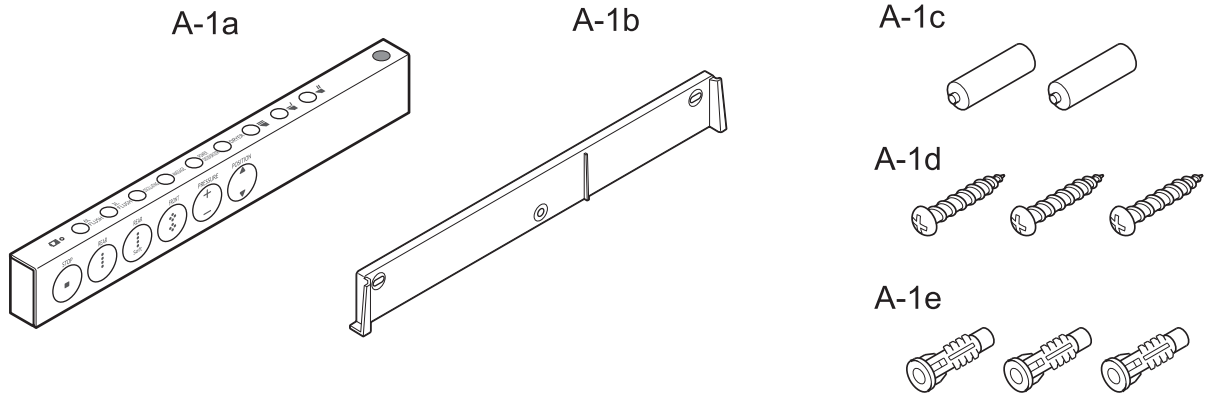

A-1f

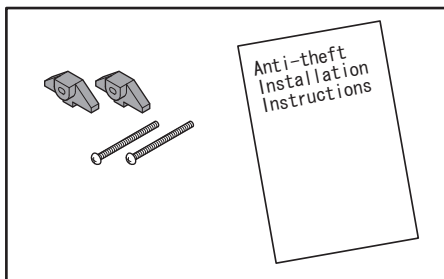

- Theft prevention parts for the remote control are included in the package. Always check with the customer before installing them. Give them to the customer if they are not installed at this time.
- Die Teile zur Diebstahlverhütung der Fernbedienung sind im Lieferumfang enthalten. Klären Sie es immer zuerst mit dem Kunden ab, bevor Sie sie anbringen. Geben Sie sie dem Kunden, wenn Sie noch nicht angebracht sind.
- Vous trouverez les éléments antivol de la télécommande dans l'emballage. Vérifiez-les toujours avec le client avant de les installer. Remettez-les au client si vous ne les installez pas de suite.
- I componenti antifurto del telecomando sono compresi nella confezione. Chiedere sempre conferma al cliente prima di installarli. Se non verranno installati subito, consegnarli al cliente.

A-2

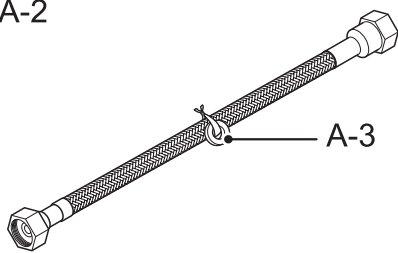

A-4

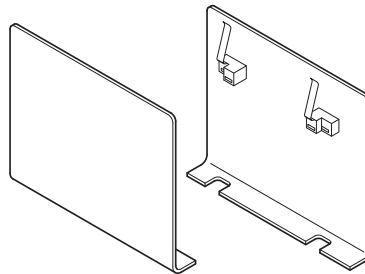

A-5

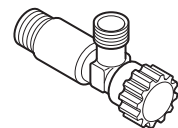

A-6

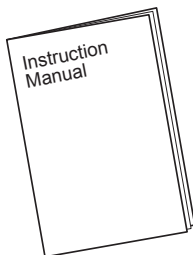

A-7

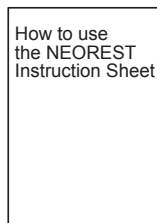

A-8



A-9



A-10

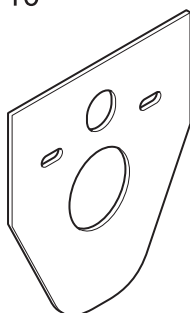

## Required tools

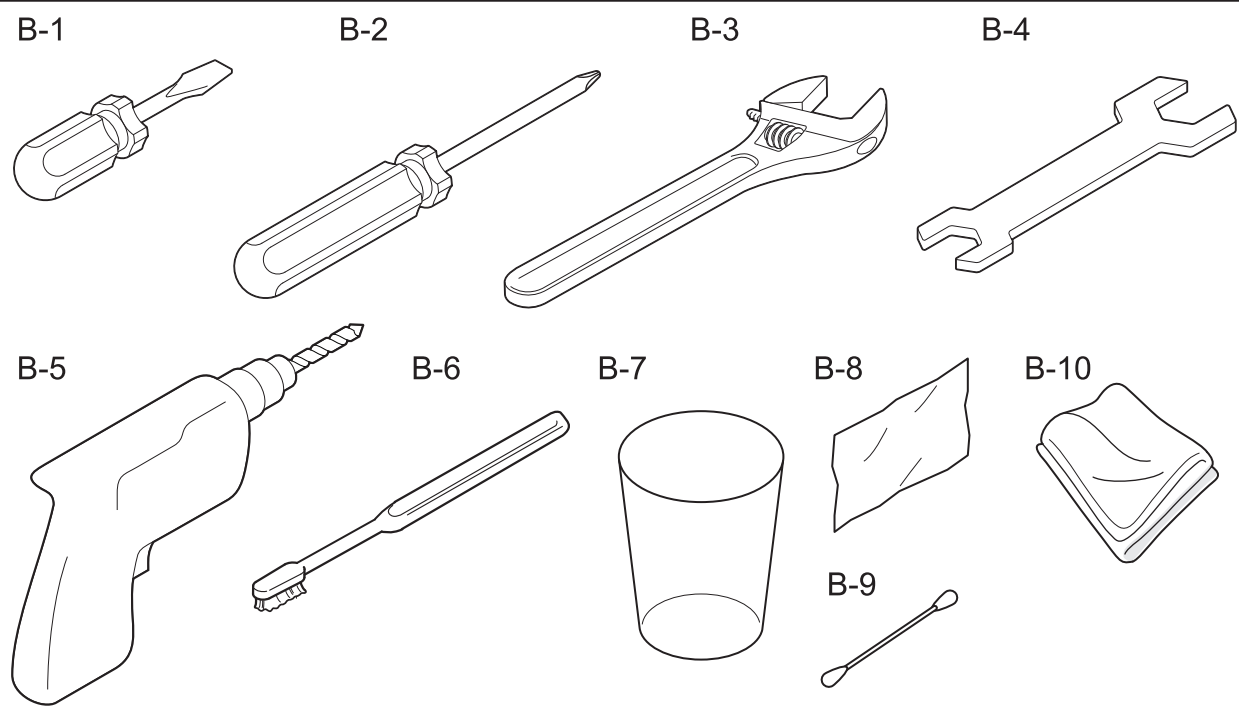

## Parts

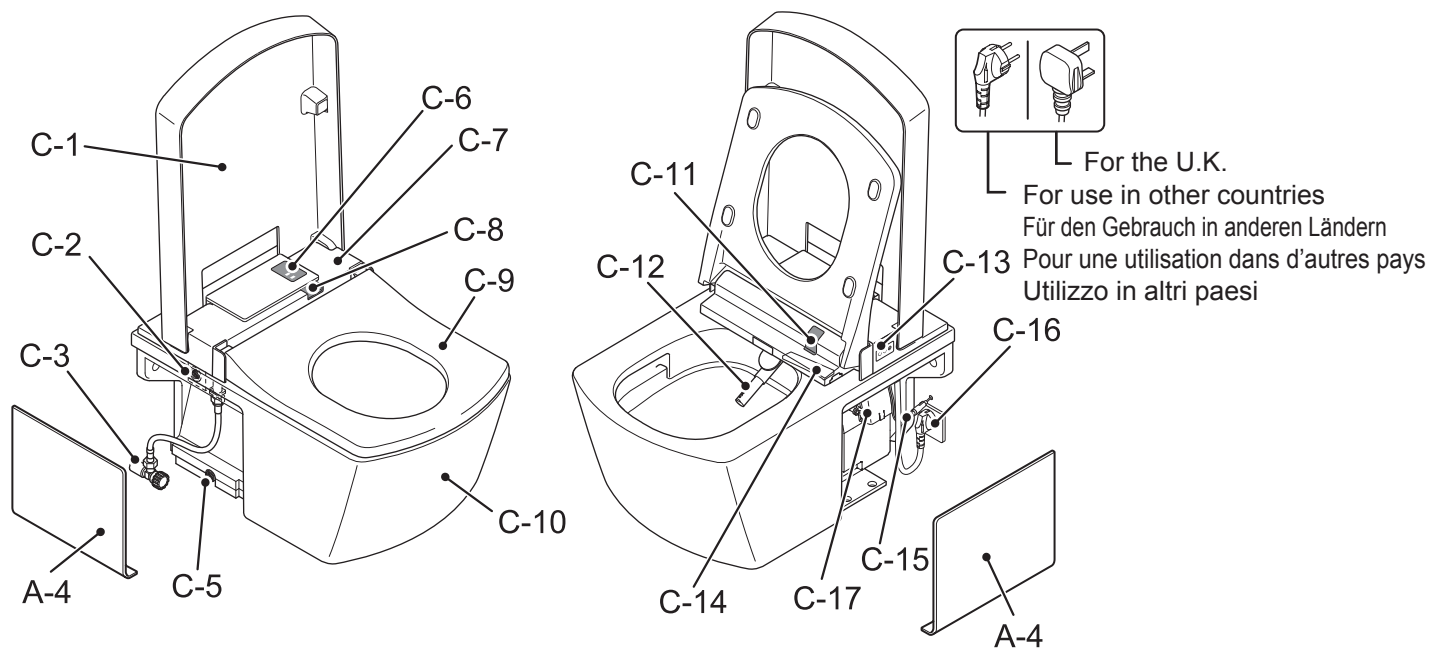

## Optional accessories

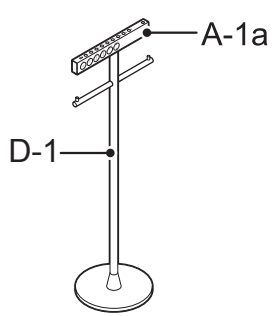

- Toilet paper stand (stock number: 00000-0)  
Recommended price:XXXXX
- Toilettenpapierständer (Produktr.: 00000-0)  
Preisempfehlung: XXXXX
- Support pour papier toilette (réf.: 00000-0)  
Prix recommandé:XXXXX
- Portarotolo (numero di serie: 00000-0)  
Prezzo di vendita consigliato: XXXXX

## Meaning of the indications

GB

↓ : Task that must be conducted by the installer

↓ : Action that the NEOREST should perform automatically

👁️ : Work that requires confirmation

⏴ : Shows the work sequence

DE

↓ : Diese Aufgabe ist vom Installateur auszuführen

↓ : Diese Funktion wird vom NEOREST automatisch ausgeführt

👁️ : Bei dieser Tätigkeit ist eine Bestätigung erforderlich

⏴ : Zeigt den Arbeitsablauf an

FR

↓ : Tâche incombant à l'installateur

↓ : Action que le NEOREST doit exécuter automatiquement

👁️ : Tâche exigeant une vérification

⏴ : Indique l'ordre de suivi de la procédure

IT

↓ : operazione che deve essere eseguita dall'installatore

↓ : operazione che il NEOREST dovrebbe eseguire automaticamente

👁️ : intervento che deve essere preceduto da verifiche

⏴ : indica la sequenza di lavoro

## Installing the NEOREST

1

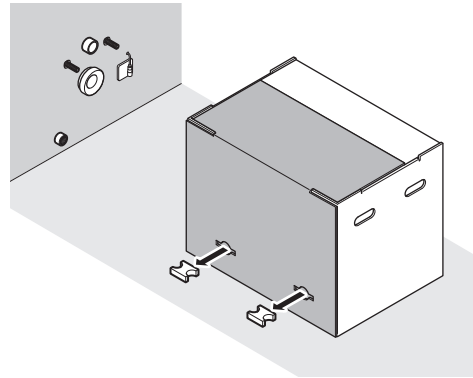

2

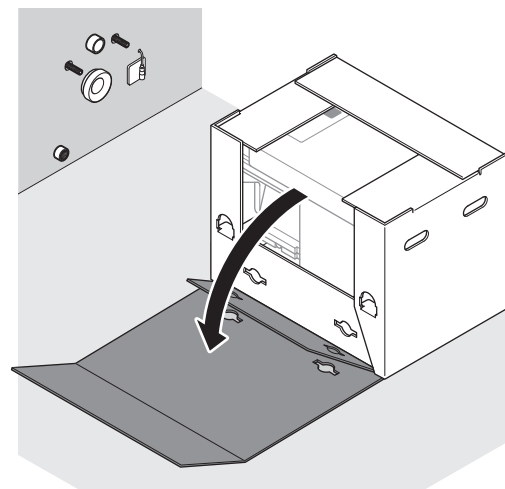

3

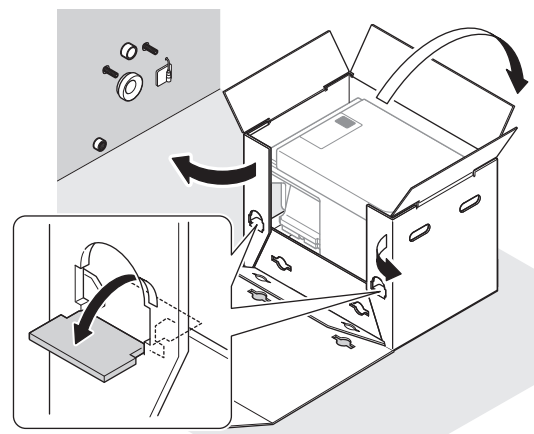

4

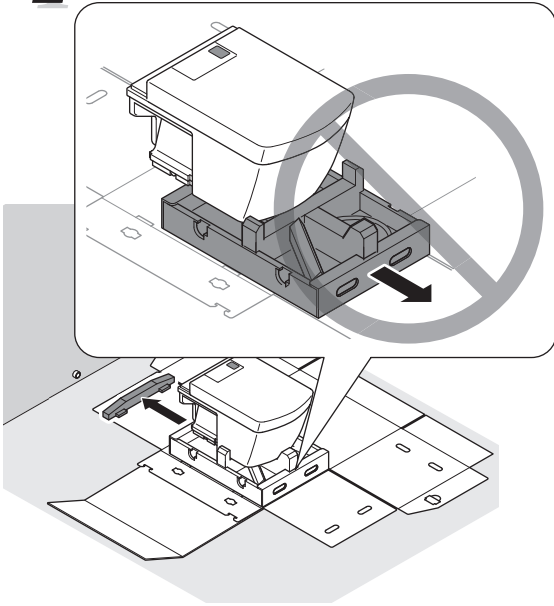

5

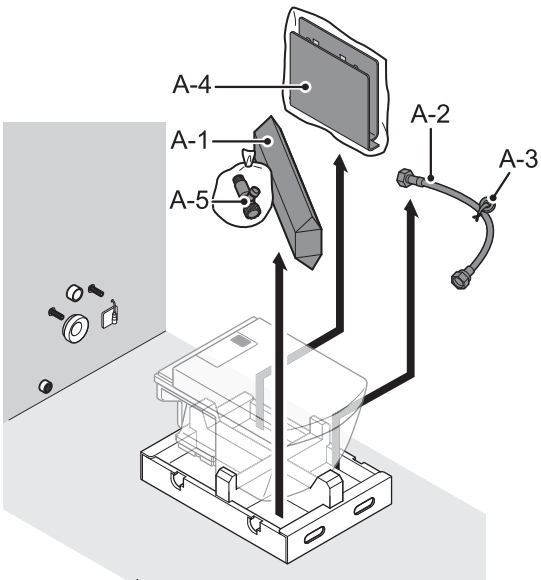

6

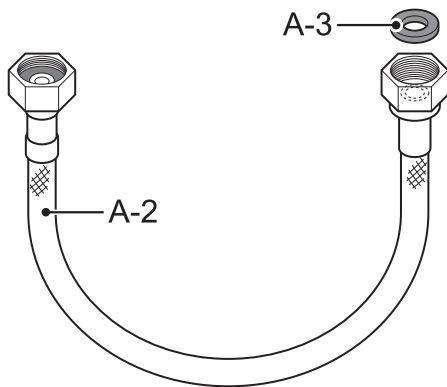

7

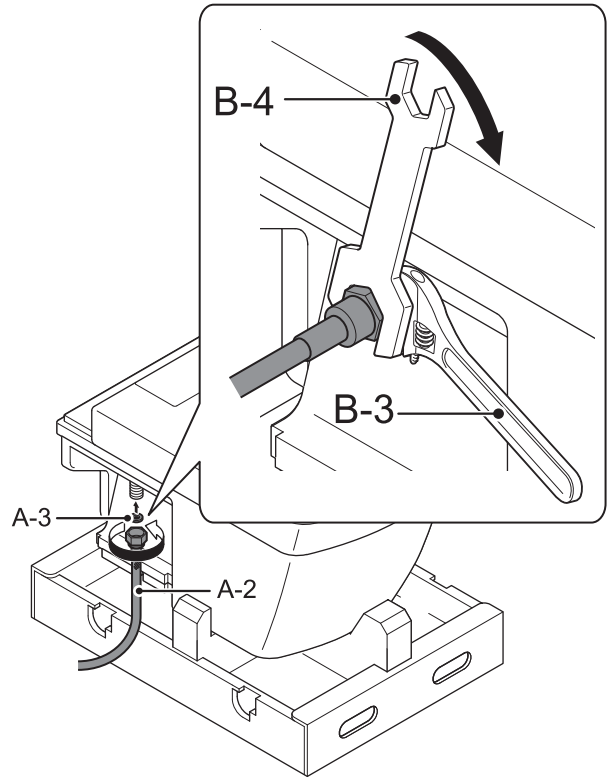

8

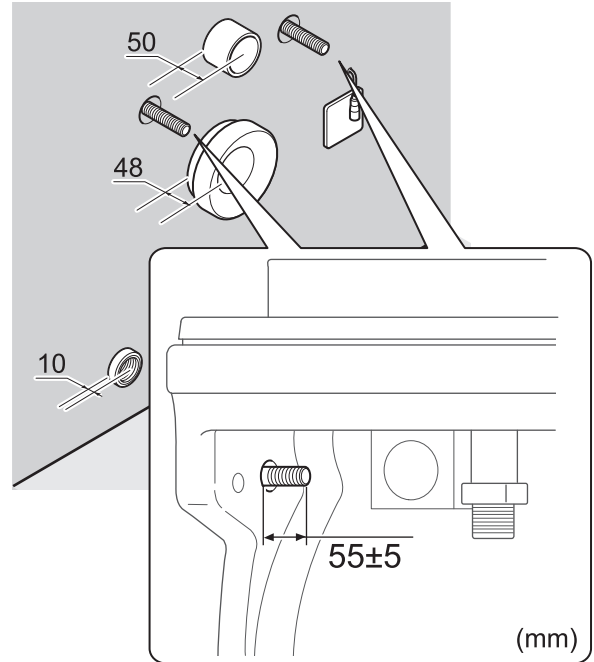

# 9

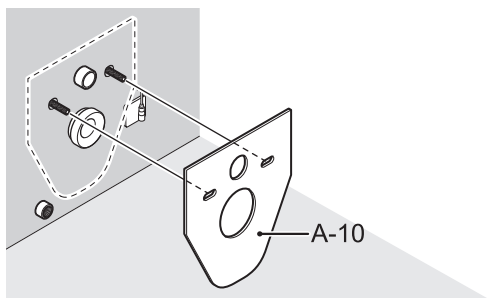

# 10

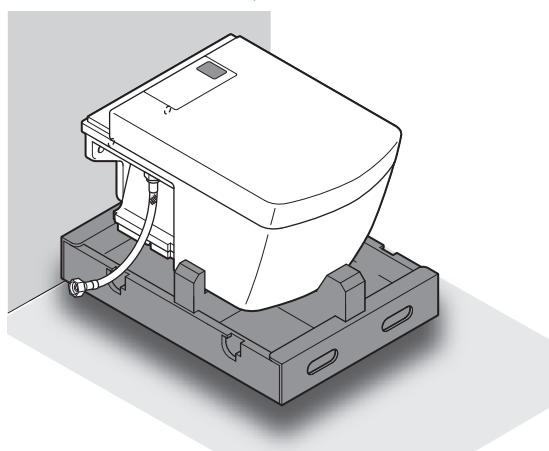
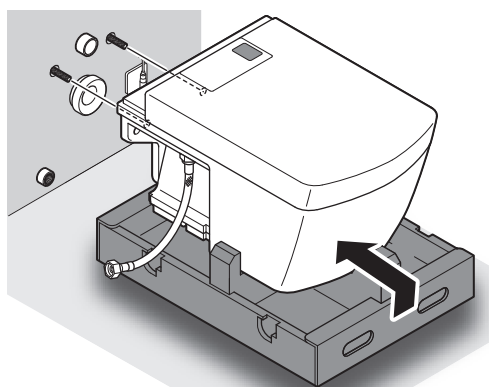

[GB]

**⚠ CAUTION**



Required

Connect the main unit securely to the toilet's water supply input and wastewater output.  
 • Incomplete connection could cause foul odours or water to leak.

[DE]

**⚠ VORSICHT**



Erforderlich

Verbinden Sie das Hauptgerät sicher mit der Wasserzufuhr und dem Wasserablauf der Toilette.  
 • Sind diese Teile nicht richtig miteinander verbunden, kann es zu unangenehmen Gerüchen oder undichten Stellen kommen.

[FR]

**⚠ MISE EN GARDE**



Requis

Raccordez convenablement l'unité principale à l'alimentation en eau et à l'évacuation des eaux usées des toilettes.  
 • Un mauvais raccordement peut entraîner le dégagement d'odeurs nauséabondes ou une fuite d'eau.

[IT]

**⚠ ATTENZIONE**



Obbligatorio

Collegare saldamente l'unità principale all'ingresso acqua del WC e all'uscita dell'acqua di scarico.  
 • Se il collegamento non viene eseguito correttamente, si potrebbero sprigionare cattivi odori oppure potrebbero verificarsi fuoriuscite d'acqua.

# 11

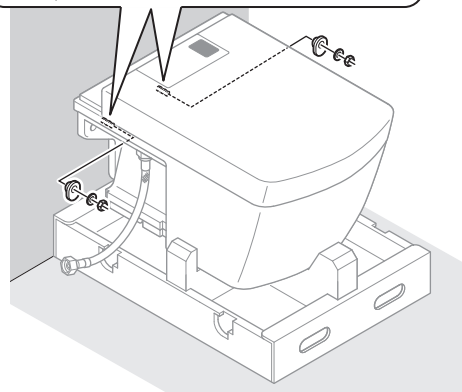
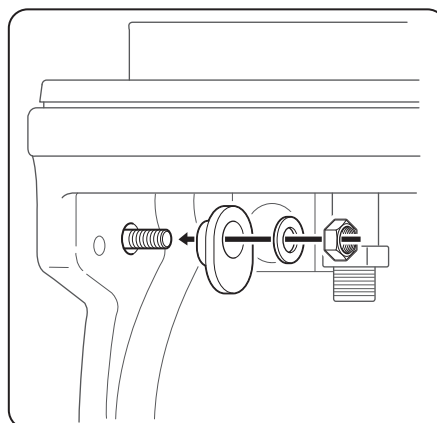

12

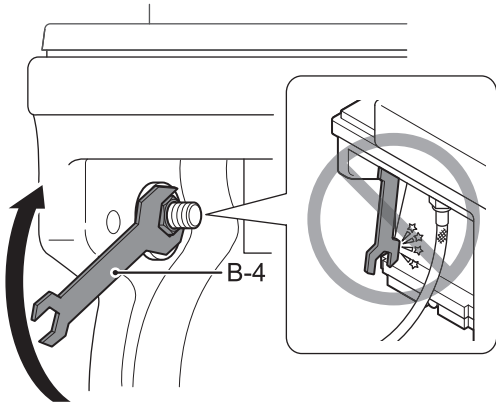

13

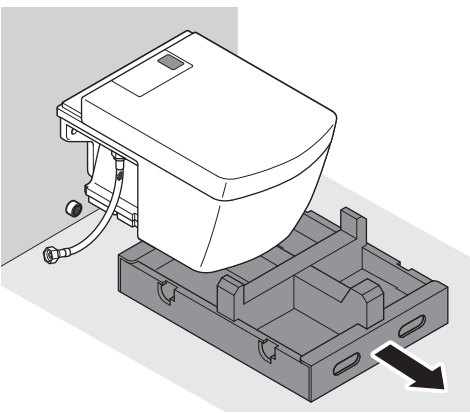

14

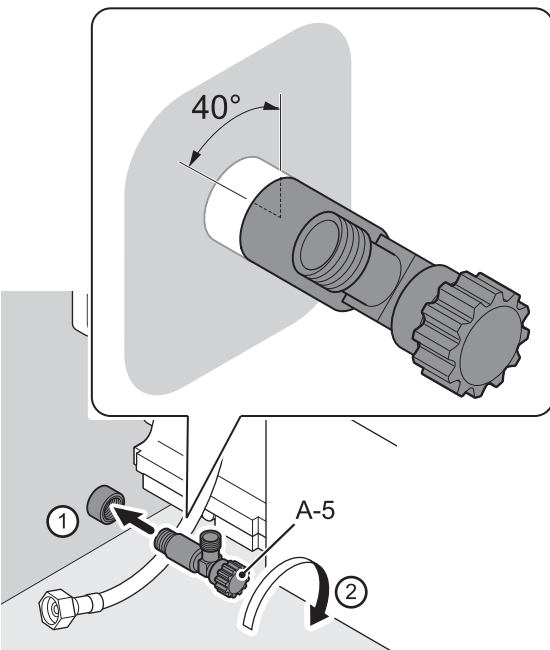

15

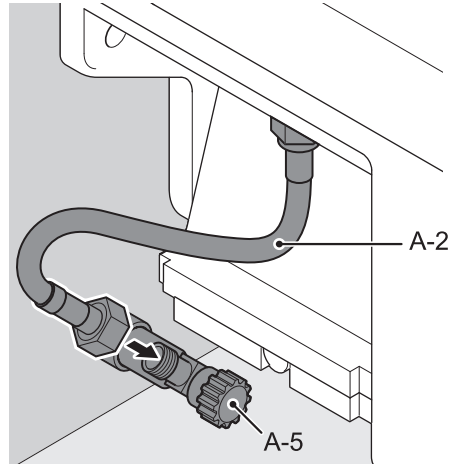



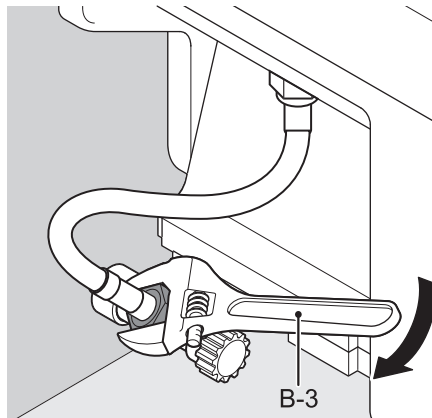

16

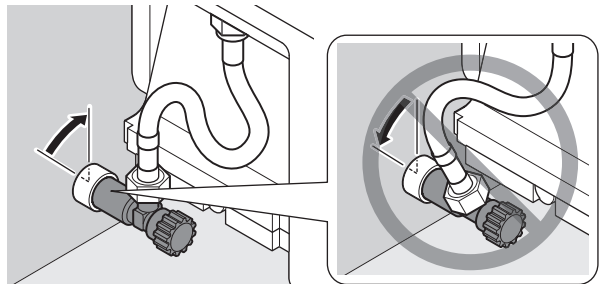

17



<b>[GB] CAUTION</b>	
 Required	Tighten the water supply hose cap nut completely. <ul style="list-style-type: none"> <li>• Failure to tighten it thoroughly could cause water to leak.</li> </ul>
<b>[DE] VORSICHT</b>	
 Erforderlich	Ziehen Sie die Hutmutter des Wasserzulaufschlauchs gut an. <ul style="list-style-type: none"> <li>• Wenn diese nicht gut angezogen ist, könnte Wasser austreten.</li> </ul>
<b>[FR] MISE EN GARDE</b>	
 Requis	Serrez à fond l'écrou borgne du flexible d'alimentation en eau. <ul style="list-style-type: none"> <li>• Si vous ne le serrez pas convenablement, une fuite d'eau est possible.</li> </ul>
<b>[IT] ATTENZIONE</b>	
 Obbligatorio	Stringere a fondo il dado cieco del tubo flessibile di ingresso acqua. <ul style="list-style-type: none"> <li>• Se non viene stretto accuratamente, si potrebbero verificare perdite d'acqua.</li> </ul>

# 18

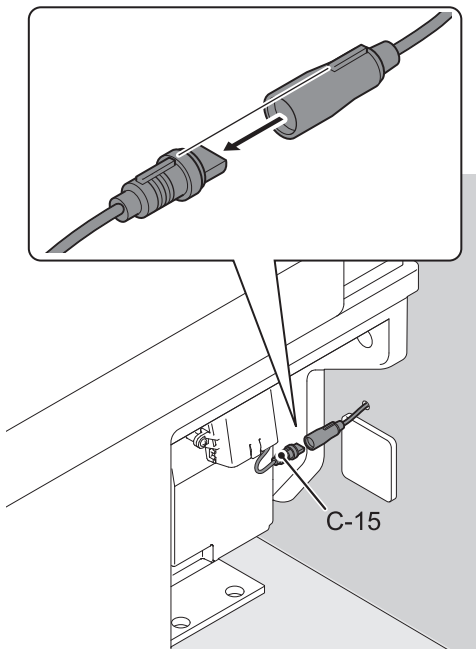

# 19

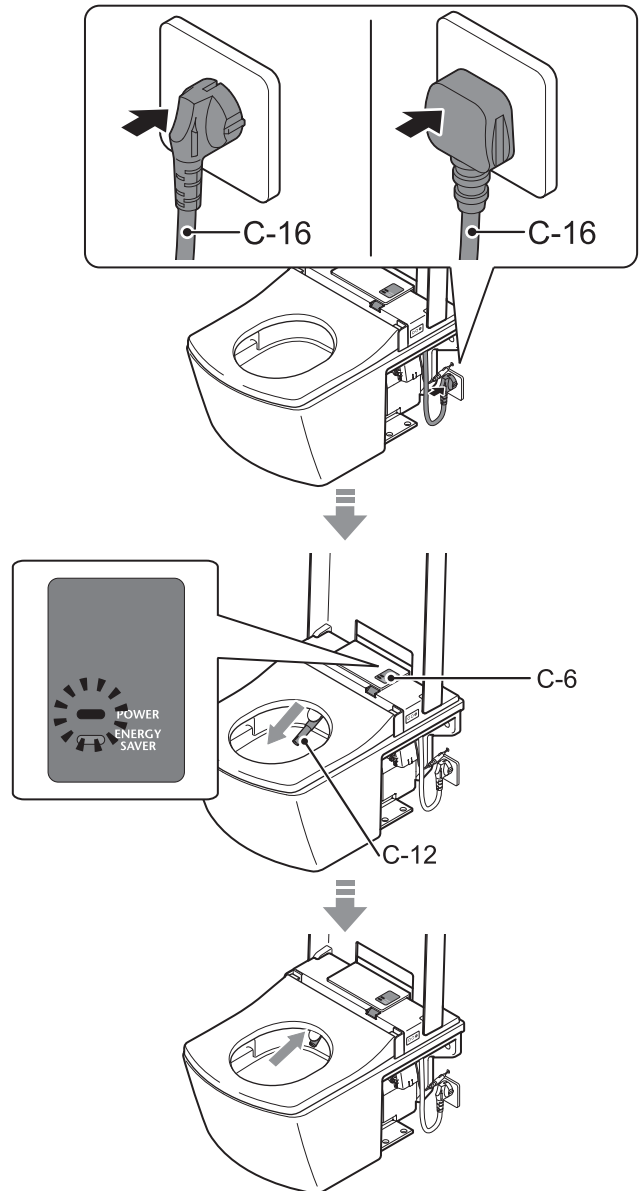

# 20

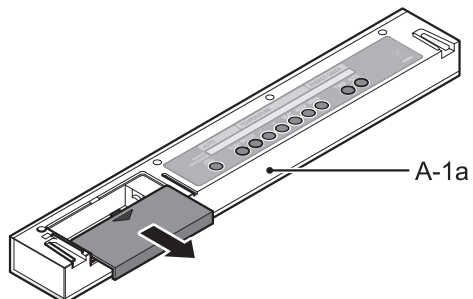

# 21

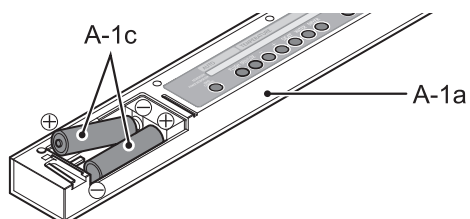



<b>[GB] CAUTION</b>	
Required	<p>Check the orientation of the remote control and attach it within the recommended area.</p> <ul style="list-style-type: none"> <li>Do not attach it in a place that people pass by or that is otherwise likely to be bumped accidentally.</li> </ul>
<b>[DE] VORSICHT</b>	
Erforderlich	<p>Überprüfen Sie die Ausrichtung der Fernbedienung und bringen Sie sie im empfohlenen Bereich an.</p> <ul style="list-style-type: none"> <li>Bringen Sie sie nicht in einem Bereich an, an dem viele Menschen vorbeigehen, da sie sonst unbeabsichtigt heruntergeworfen werden könnte.</li> </ul>
<b>[FR] MISE EN GARDE</b>	
Requis	<p>Vérifiez l'orientation de la télécommande et fixez-la au sein de la zone prescrite.</p> <ul style="list-style-type: none"> <li>Ne la fixez pas dans un lieu de passage ou à un endroit où elle risque d'être heurtée par inadvertance.</li> </ul>
<b>[IT] ATTENZIONE</b>	
Obbligatorio	<p>Controllare l'orientamento del telecomando e fissarlo nell'area consigliata.</p> <ul style="list-style-type: none"> <li>Non fissarlo in un punto di passaggio o in altri luoghi in cui potrebbe essere urtato accidentalmente.</li> </ul>

## 22

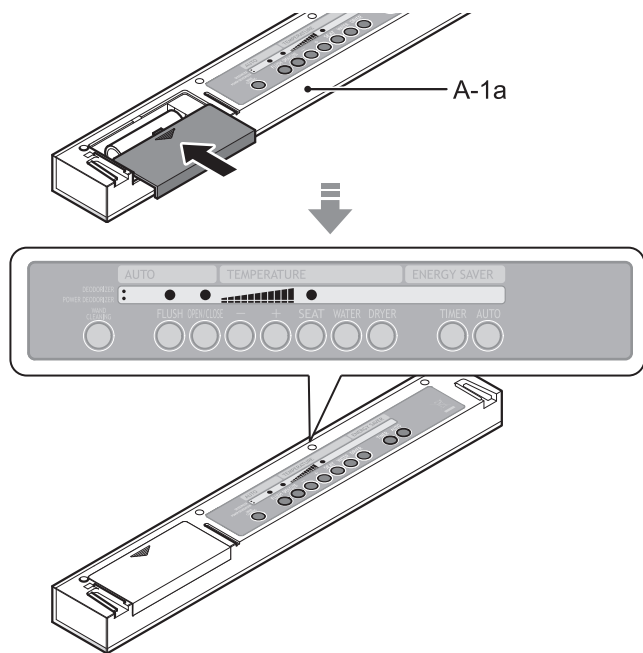

## 23

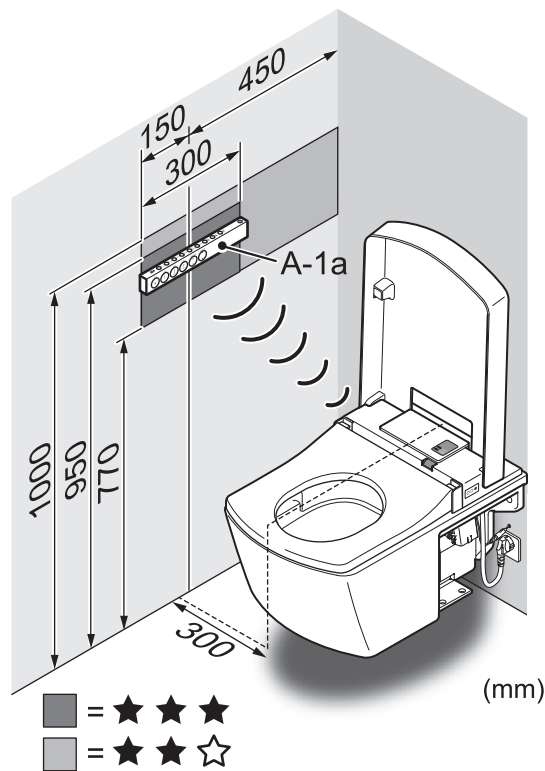

## 24

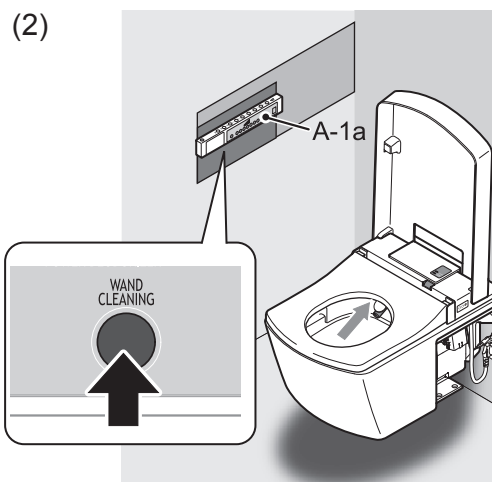
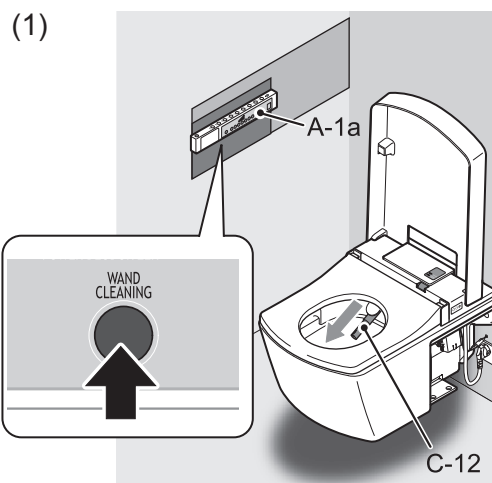

# 25

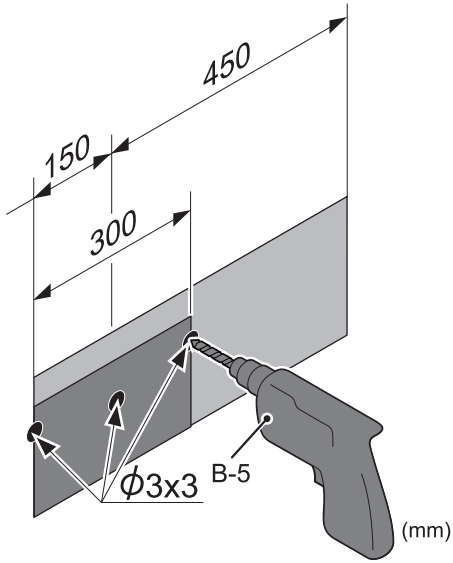

# 26

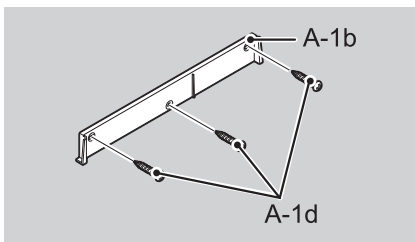

**With a plasterboard or tile wall.**

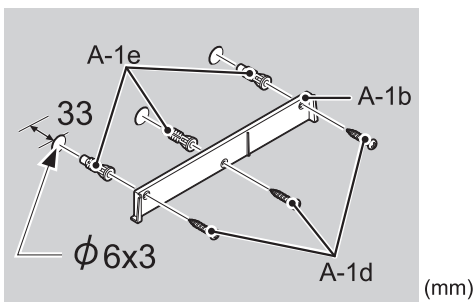

# 27

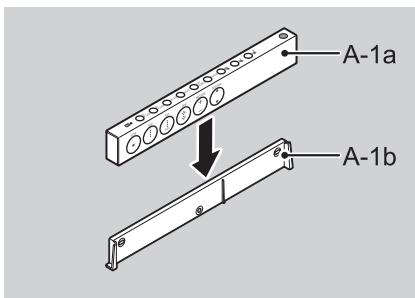

See the included instructions for how to attach the theft prevention parts.

**When using a toilet paper stand.**

# 28

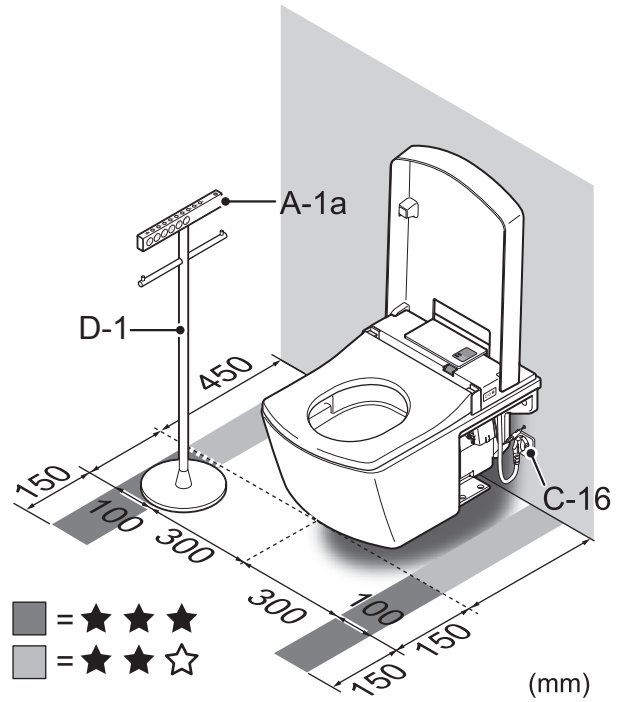

# Testing the operation of the NEOREST

## 1

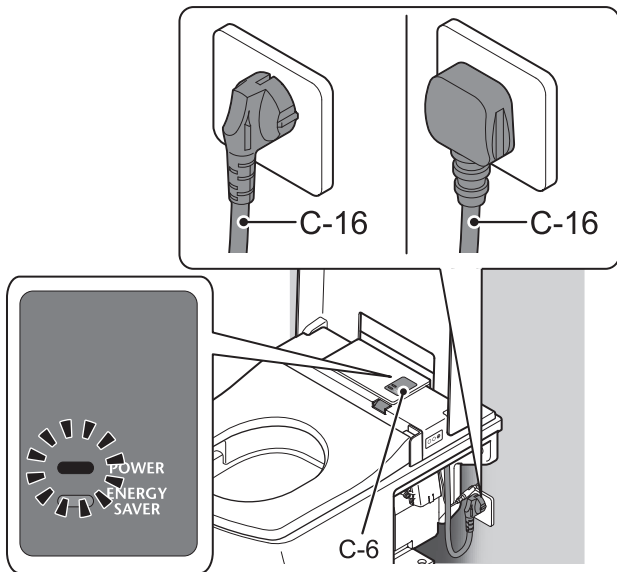

If the power indicator is not lit in step 1.

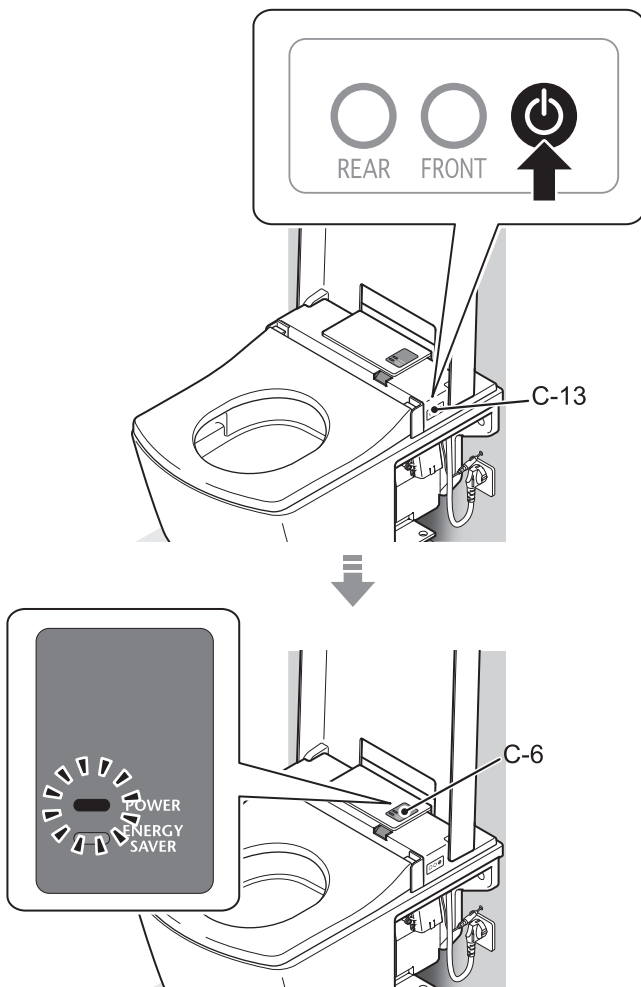

## 2

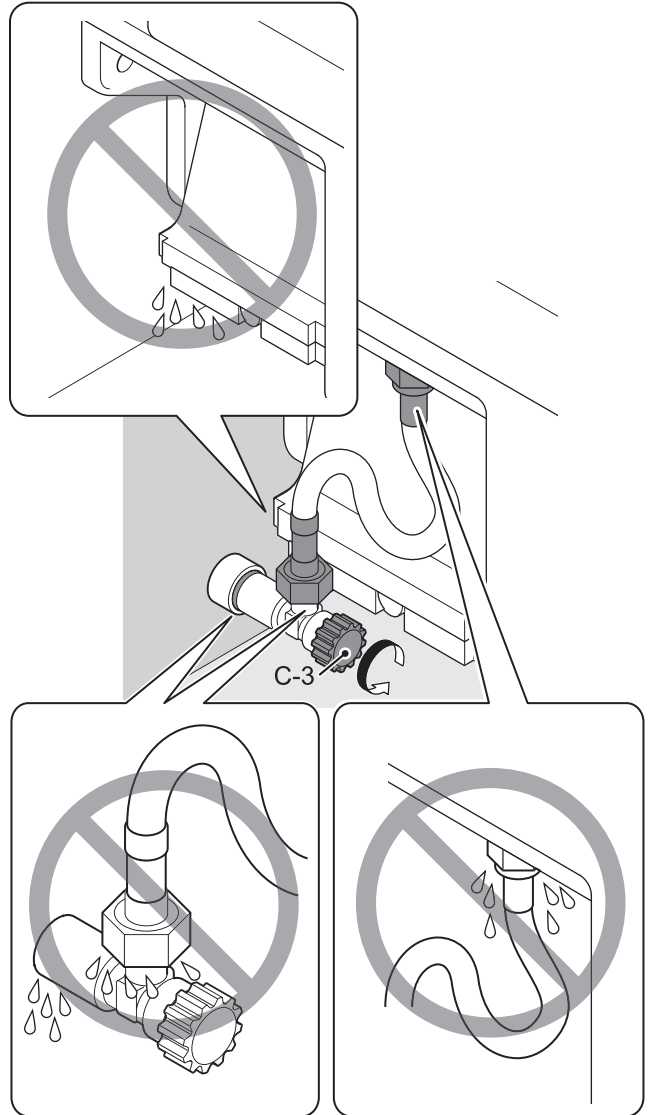

## 3

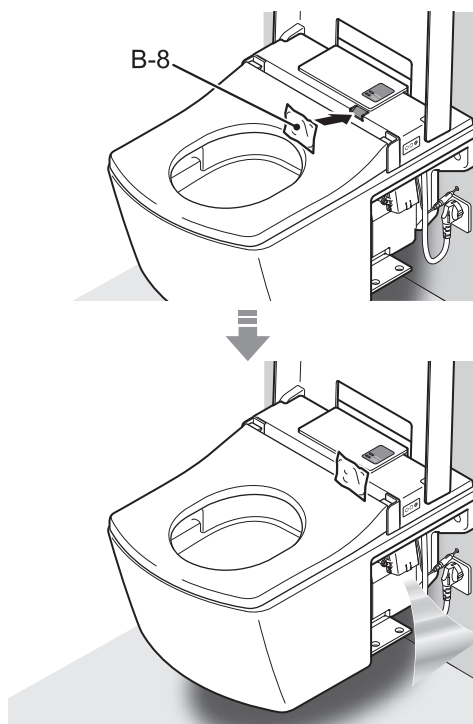

# 4

(1)

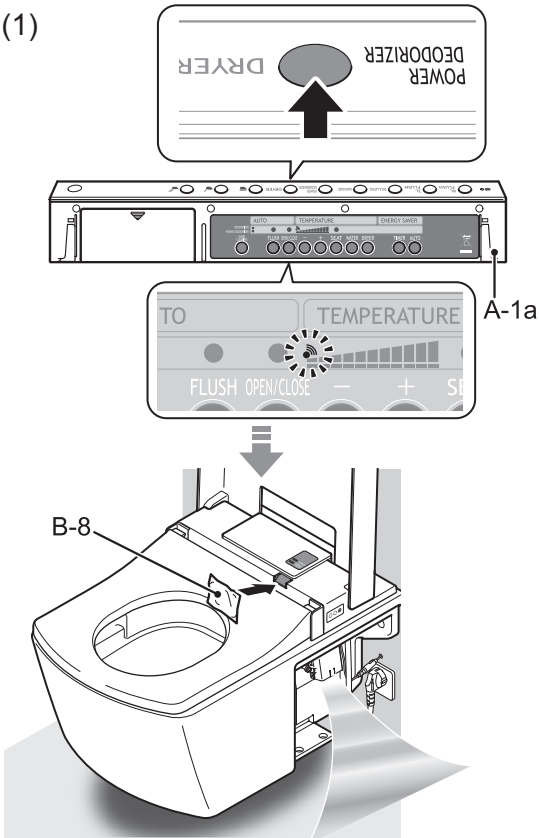

(2)

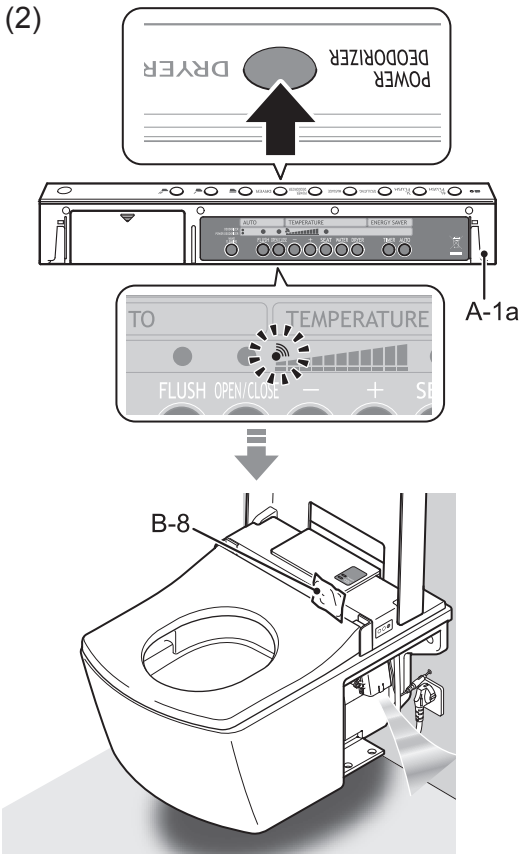

# 5

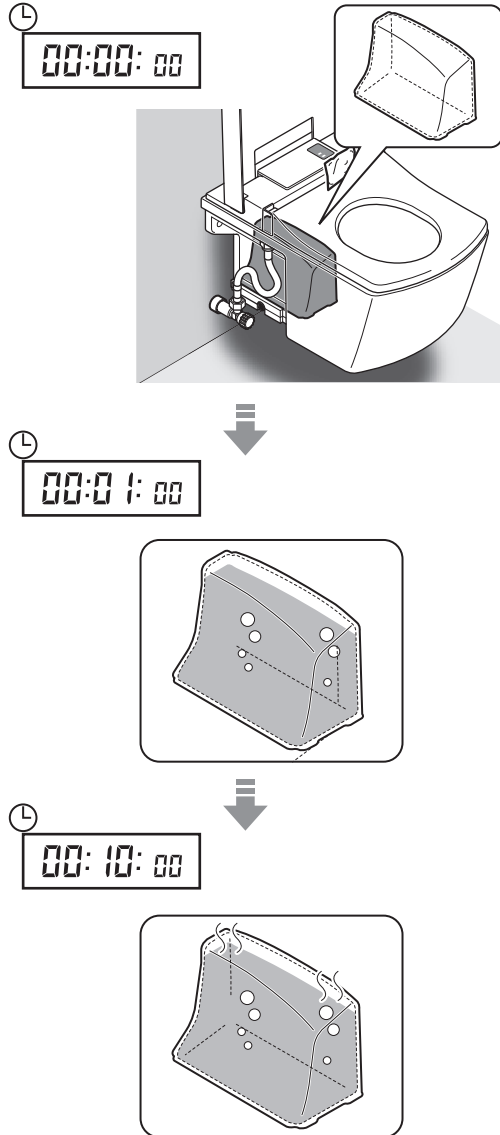

# 6

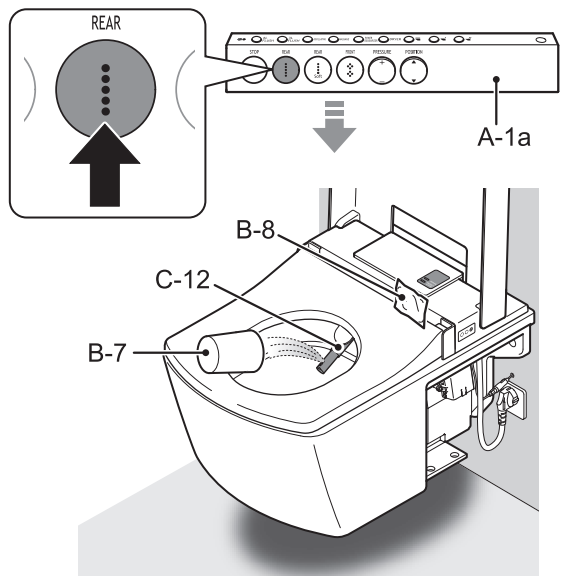

# 7

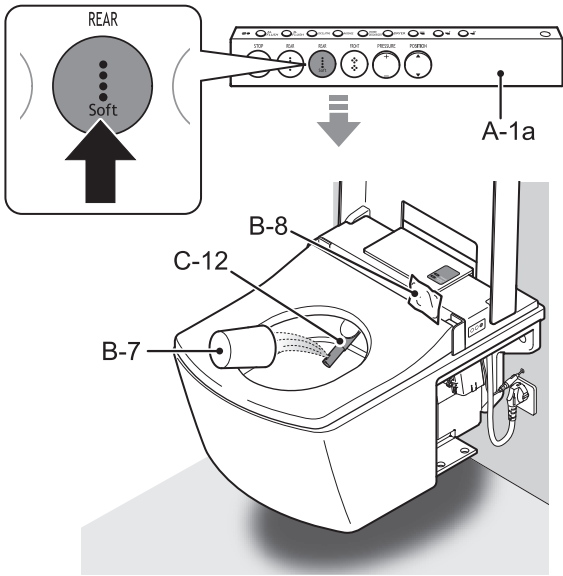

# 10

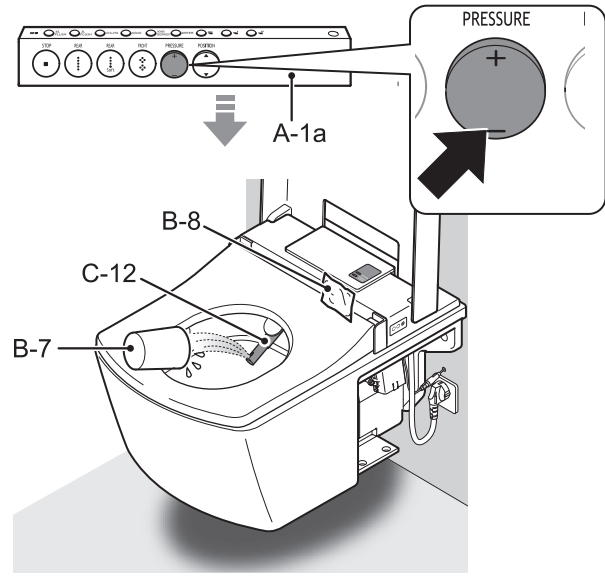

# 8

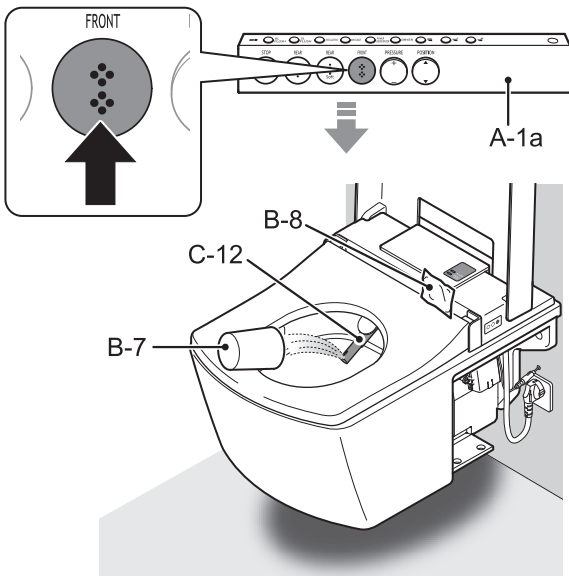

# 11

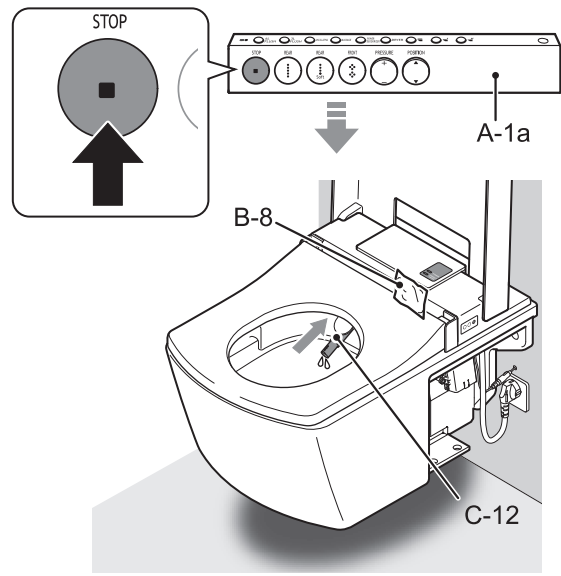

# 9

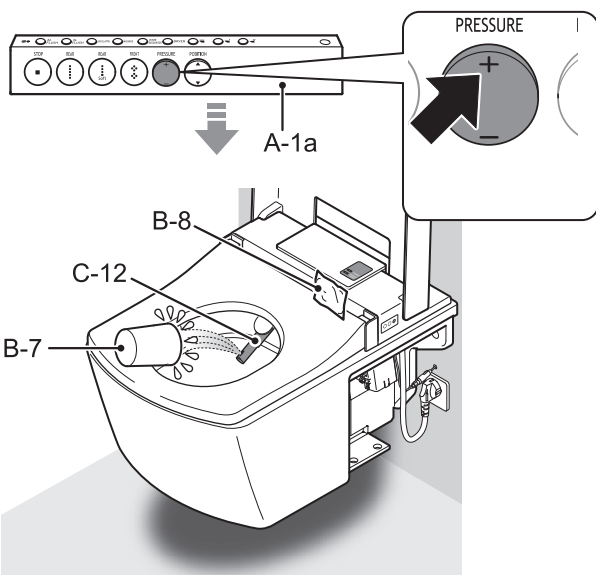

# 12

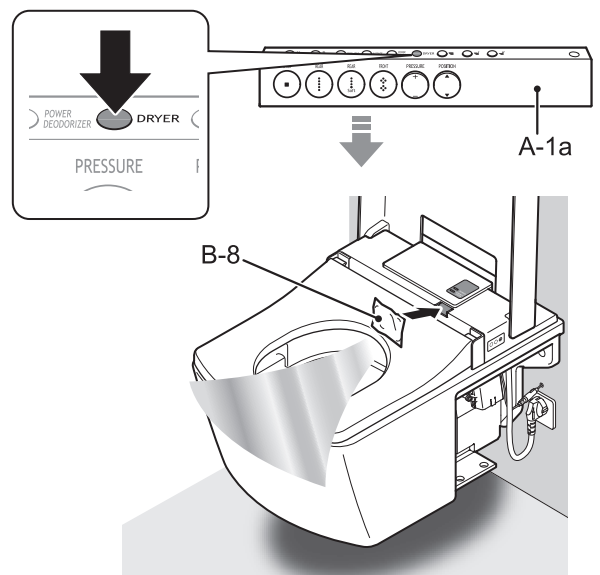

Others

# 13

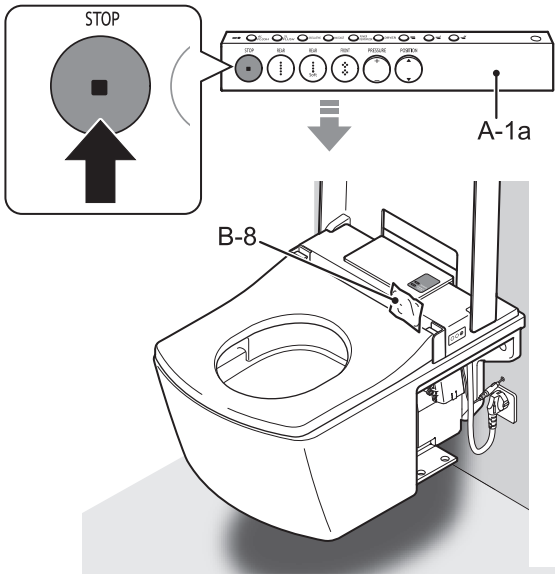

# 15

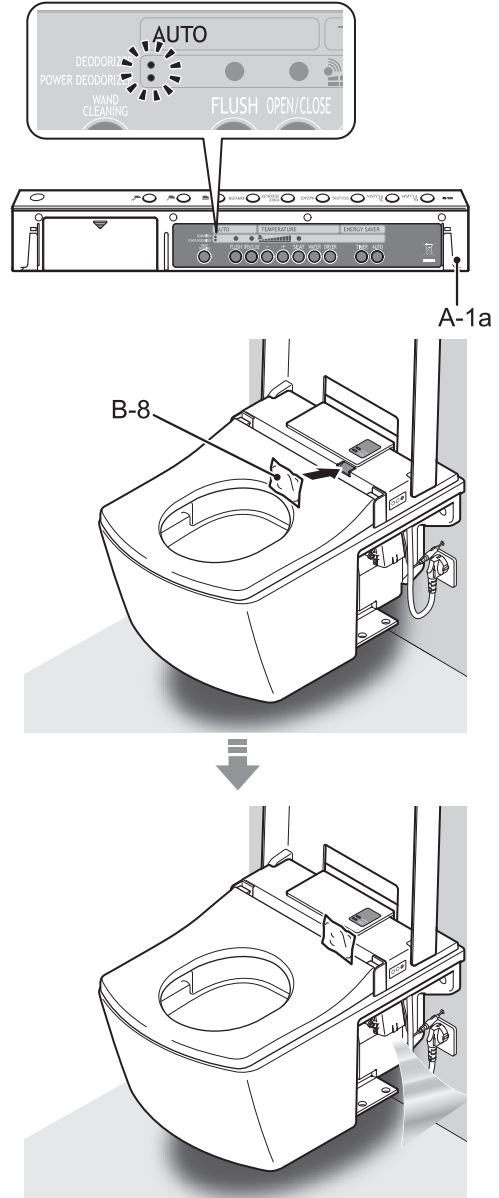

# 14

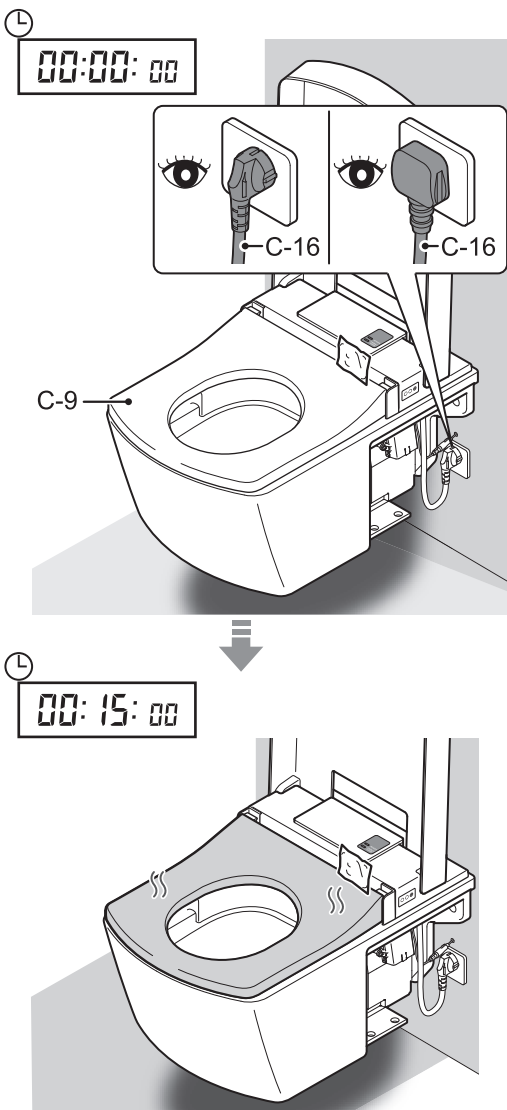

# 16



00:00:00

B-8

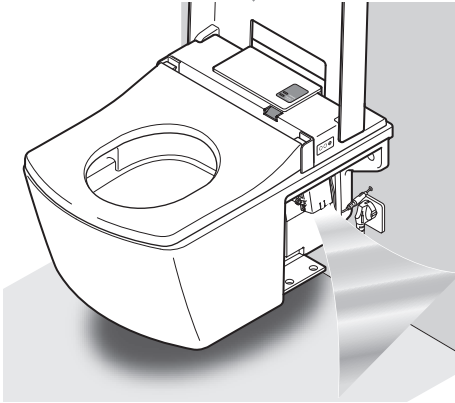
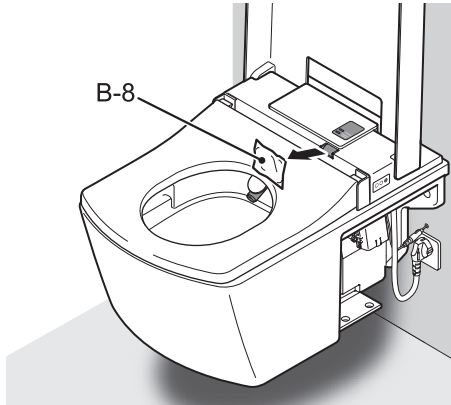

00:02:00

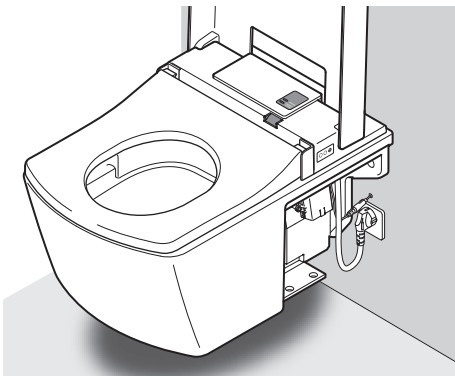

# 17



00:00:00

C-9

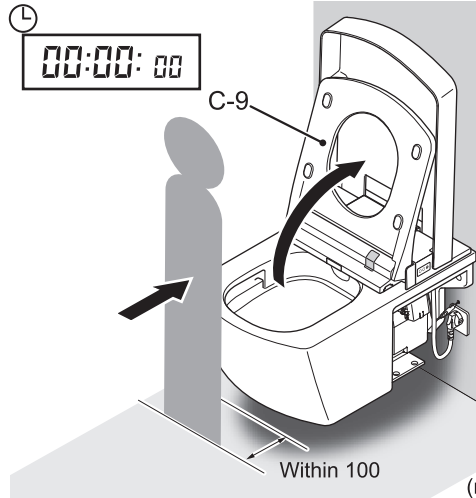

00:00:06

C-9

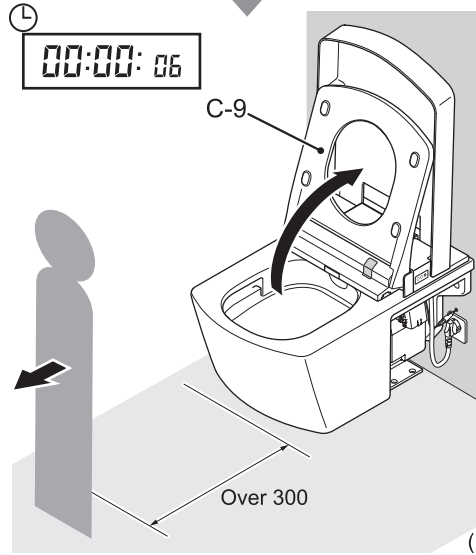

00:00:09

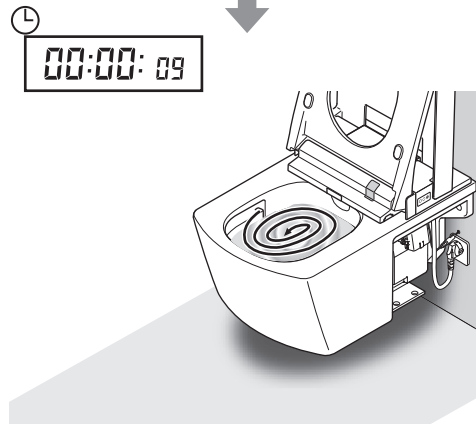

(1)

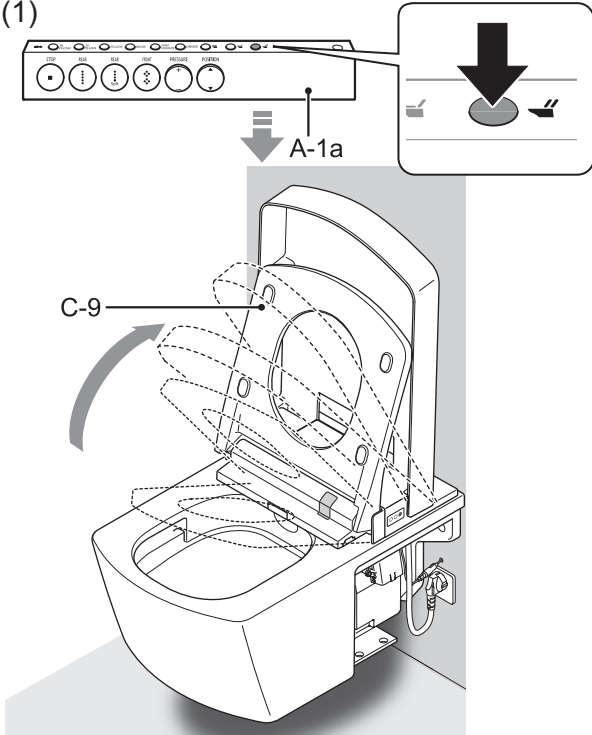

(2)

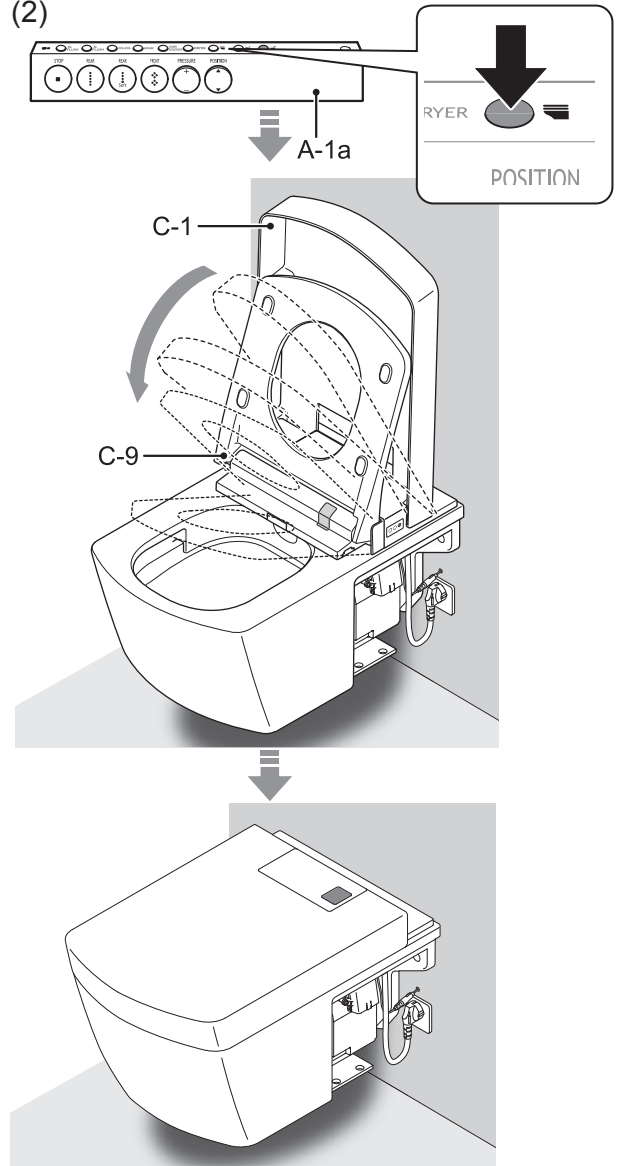

(3)

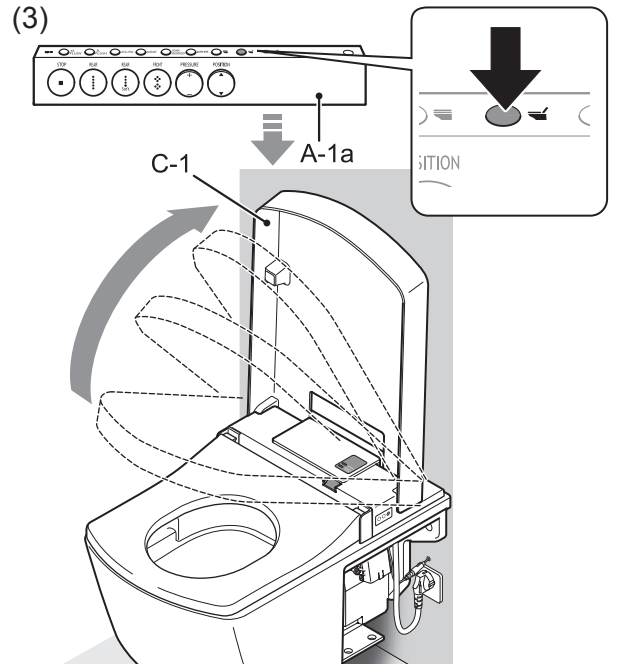



# 19

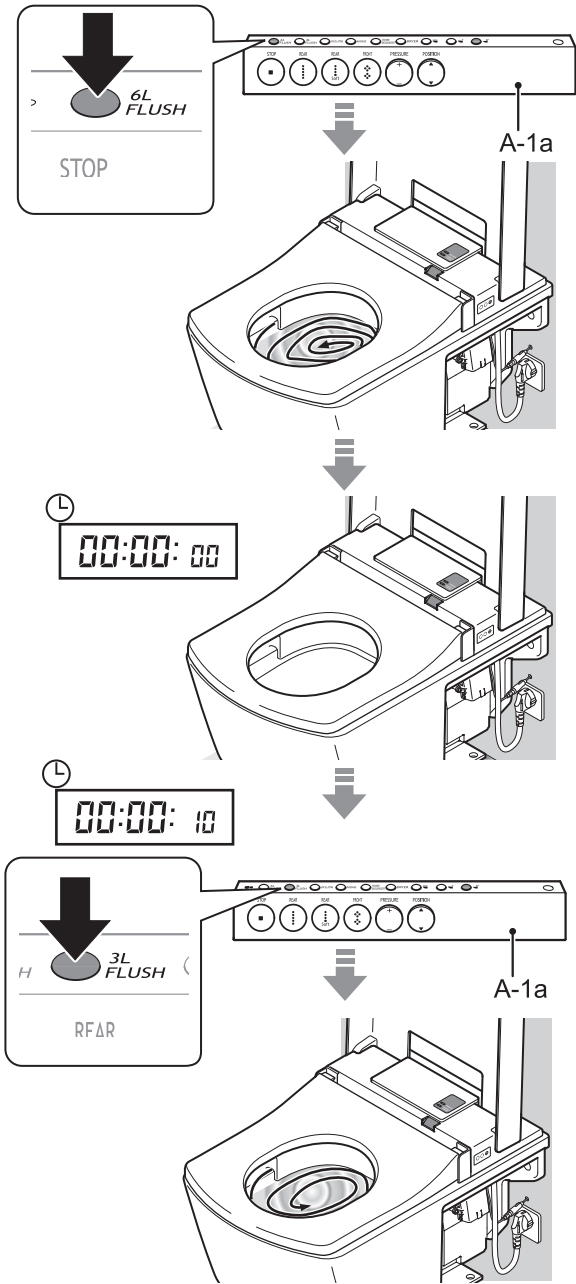

# 20

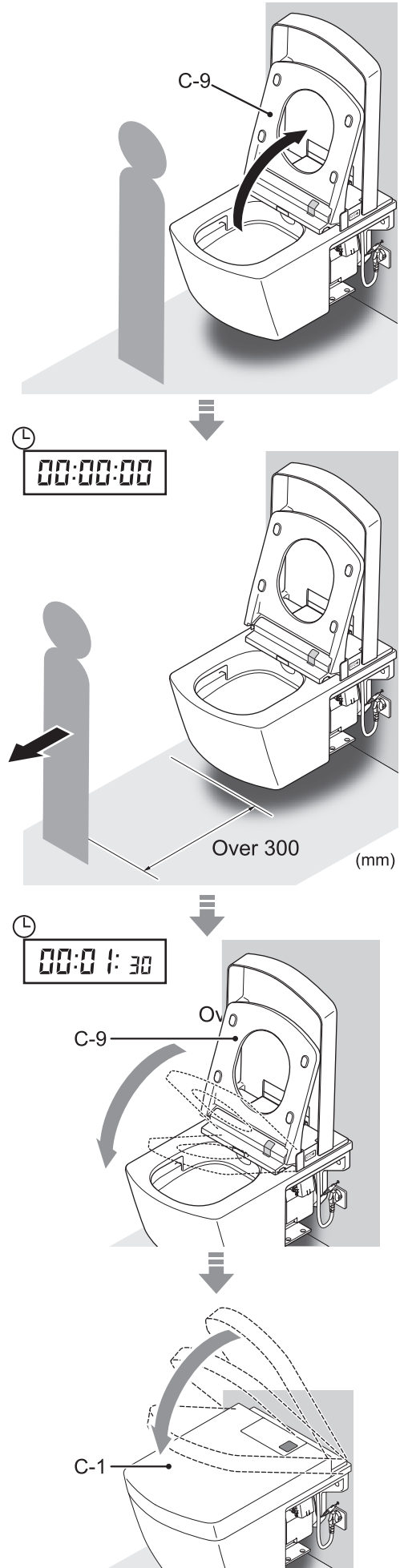

Others

# 21

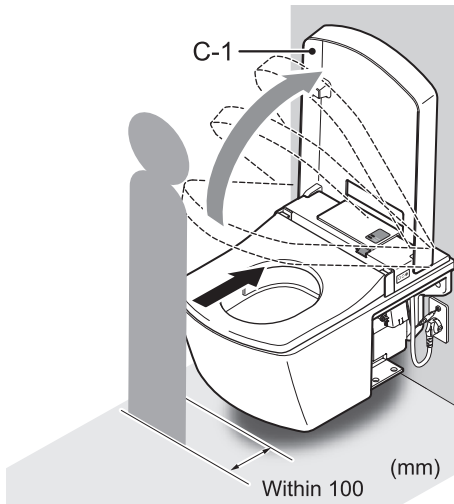

If the lid does not open automatically in step 21.

# 22

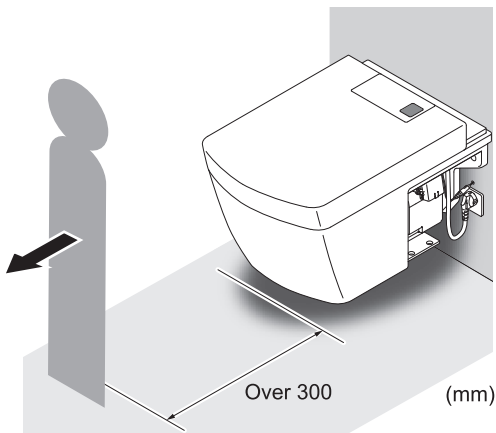

# 23

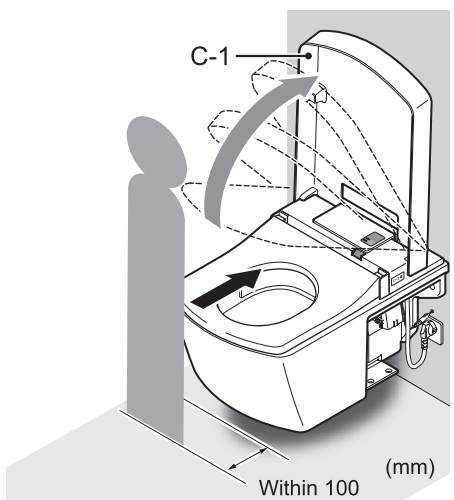

## Cleaning the water supply filter

# 1

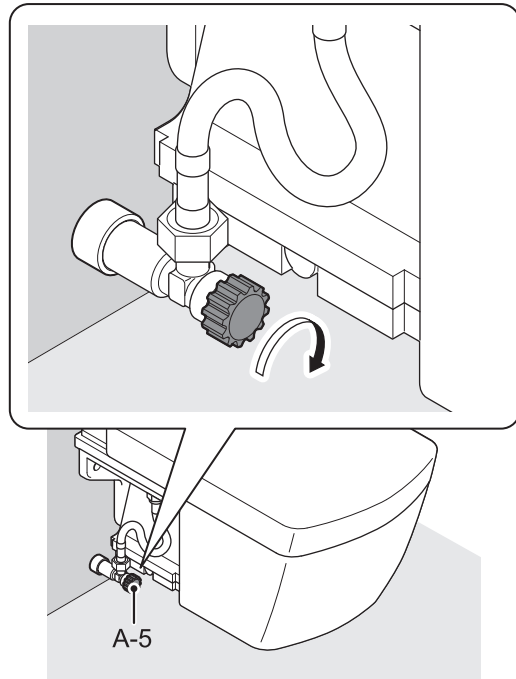

[GB]

**CAUTION**



Required

Do not detach the drain valve with built-in water filter while the water shut-off valve is still open.

- Doing so will cause water to spill.

[DE]

**VORSICHT**



Erforderlich

Nehmen Sie das Ablaufventil mit eingebautem Wasserfilter nicht ab, solange das Wasserabsperrventil geöffnet ist.

- Andernfalls strömt Wasser aus.

[FR]

**MISE EN GARDE**



Requis

Ne détachez pas le robinet de vidange avec filtre à eau intégré lorsque le robinet de sectionnement est encore ouvert.

- De l'eau pourrait se déverser.

[IT]

**ATTENZIONE**



Obbligatorio

Non staccare la valvola di scarico con filtro dell'acqua incorporato mentre la valvola di chiusura acqua è ancora aperta.

- In caso contrario, si verificheranno fuoriuscite di acqua.

# 2

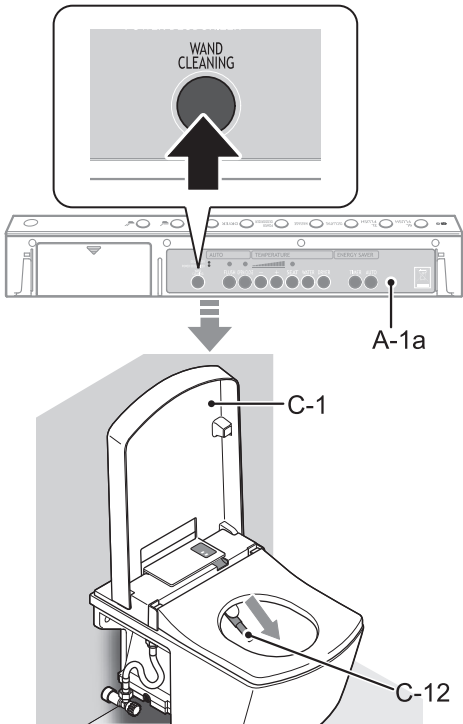

# 3

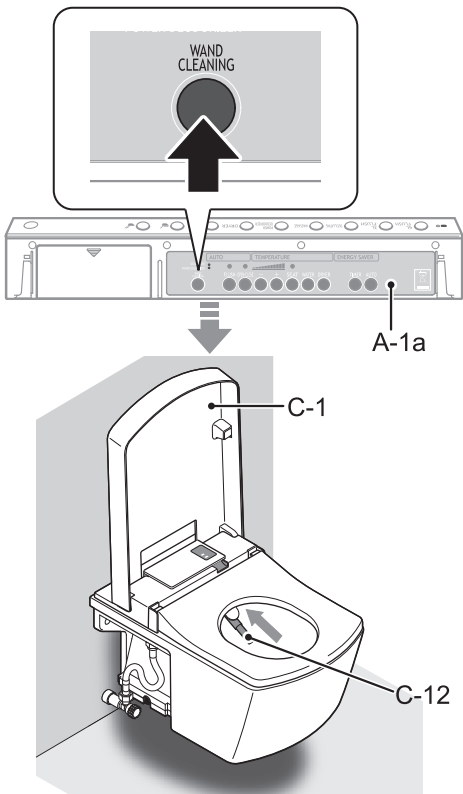

# 4

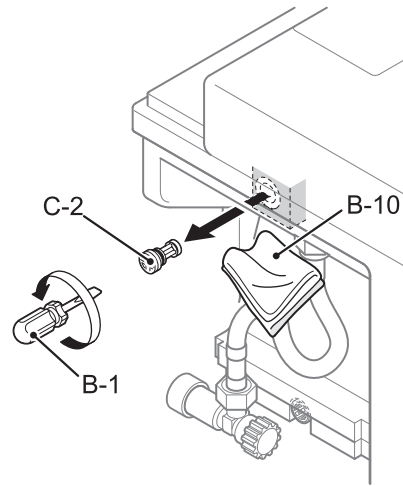



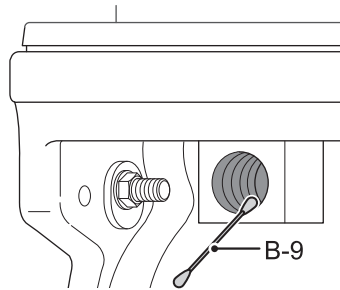
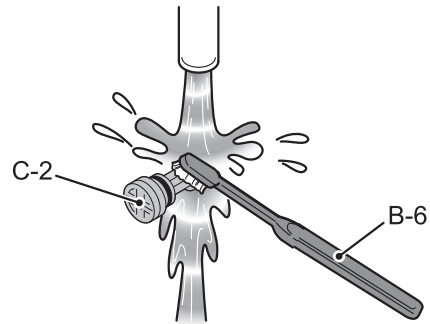

# 5

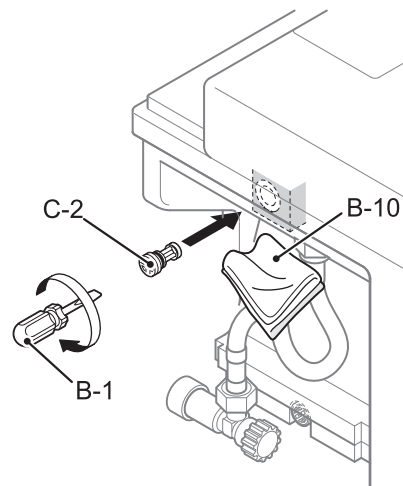

# 6



<b>[GB] CAUTION</b>	
 Required	Thoroughly tighten the drain valve with built-in water filter. • Failure to do so could cause a water leak.
<b>[DE] VORSICHT</b>	
 Erforderlich	Befestigen Sie das Ablaufventil mit eingebautem Wasserfilter gut. • Ansonsten kann Wasser austreten.
<b>[FR] MISE EN GARDE</b>	
 Requis	Serrez fermement le robinet de vidange avec fi ltre à eau intégré. • Le non-respect de cette mise en garde pourrait entraîner une fuite.
<b>[IT] ATTENZIONE</b>	
 Obbligatorio	Stringere a fondo la valvola di scarico con fi ltro dell'acqua incorporato. • In caso di mancata osservanza di questa avvertenza si potrebbero verifi care fuoriuscite di acqua.

# 7

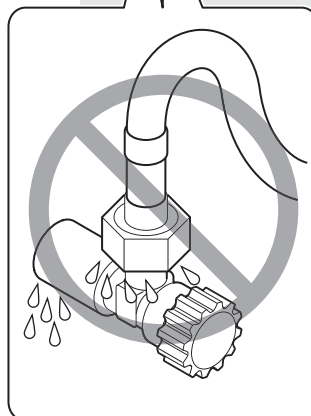
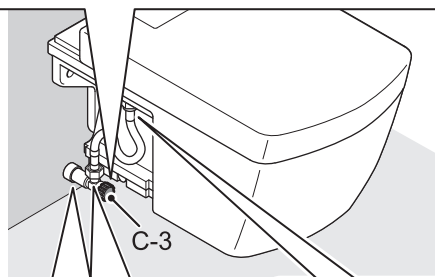
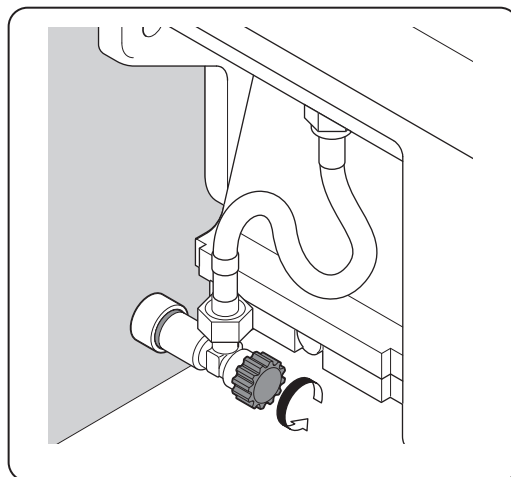

# Attaching the cover panels

1

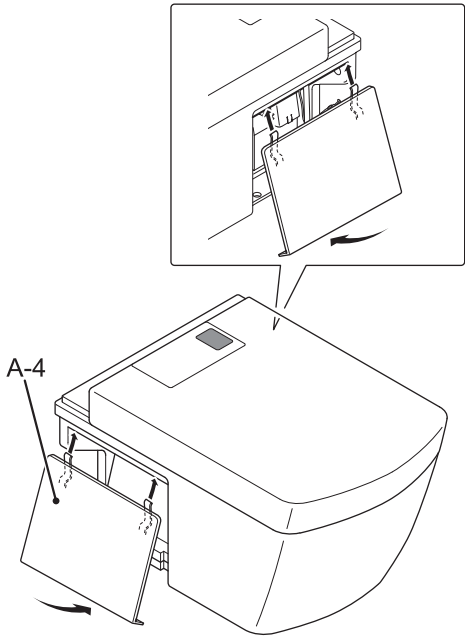

2

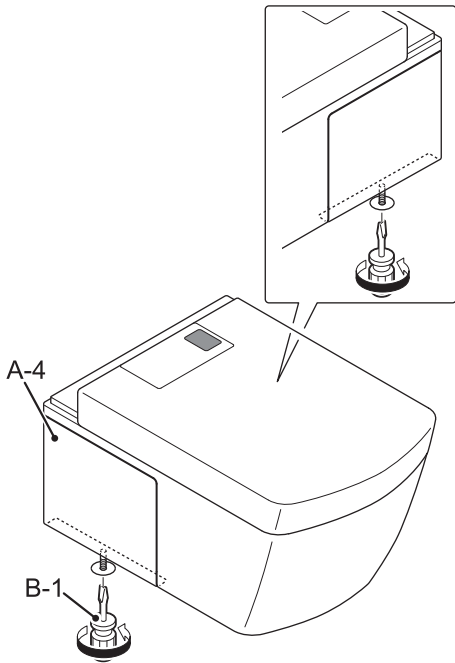

**TOTO®**